

EVALUATION KIT
AVAILABLE



4-Wire Serially Interfaced 8 x 8 Matrix Graphic LED Drivers

General Description

The MAX6960–MAX6963 are compact cathode-row display drivers that interface microprocessors to 8 x 8 dot-matrix red, green, and yellow (R,G,Y) LED displays through a high-speed 4-wire serial interface.

The MAX6960–MAX6963 drive two monochrome 8 x 8 matrix displays, or a single RGY 8 x 8 matrix display with no external components. The driver can also be used with external pass transistors to control red, green, blue (RGB) and other displays at higher currents and voltages.

The MAX6960–MAX6963 feature open- and short-circuit LED detection, and provide both analog and digital tile segment current calibration to allow 8 x 8 displays from different batches to be compensated or color matched.

A local 3-wire bus synchronizes multiple interconnected MAX6960–MAX6963s and automatically allocates memory map addresses to suit the user's display-panel architecture.

The MAX6960–MAX6963s' 4-wire interface connects multiple drivers, with display memory mapping shared and allocated among the drivers. A single global write operation can send a command to all MAX6960s in a panel.

The MAX6963 drives monochrome displays with two-step intensity control. The MAX6962 drives monochrome displays with two-step or four-step intensity control. The MAX6961 drives monochrome or RGY displays with two-step intensity control. The MAX6960 drives monochrome or RGY displays with two-step or four-step intensity control.

Pin Configurations

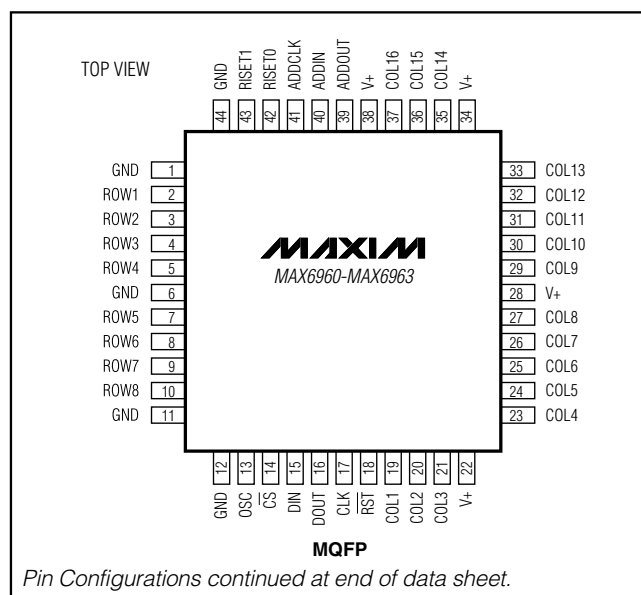

Features

- ◆ 2.7V to 3.6V Operation
- ◆ High-Speed 20MHz Serial Interface
- ◆ Trimmed 40mA or 20mA Peak Segment Current
- ◆ Directly Drives Either Two Monochrome or One RGY Cathode-Row 8 x 8 Matrix Displays
- ◆ Analog Digit-by-Digit Segment Current Calibration
- ◆ Digital Digit-by-Digit Segment Current Calibration
- ◆ 256-Step Panel Intensity Control (All Drivers)
- ◆ Four Steps per Color Pixel-Level Intensity Control
- ◆ Open/Short LED Detection
- ◆ Burst White to Display Memory Planes
- ◆ Global Command Access All Devices
- ◆ Can Control RGB Panels or Higher Current/Voltage Panels with External Pass Transistors
- ◆ Multiple Display Data Planes Ease Animation
- ◆ Automatic Plane Switching from 63 Planes per Second to One Plane Every 63s, with Interrupt
- ◆ Slew-Rate-Limited Segment Drivers for Lower EMI
- ◆ Driver Switching Timing Can Be Spread Between Multiple Drivers to Flatten Power-Supply Peak Demand
- ◆ Low-Power Shutdown with Full Data Retention
- ◆ -40°C to +125°C Temperature Range

Applications

Message Boards Industrial Controls
Gaming Machines Audio/Video Equipment

Ordering Information

PART	TEMP RANGE	PIN-PACKAGE	PKG CODE
MAX6960AMH	-40°C to +125°C	44 MQFP	—
MAX6960ATH	-40°C to +125°C	44 TQFN-EP*	T4477-3
MAX6961AMH	-40°C to +125°C	44 MQFP	—
MAX6961ATH	-40°C to +125°C	44 TQFN-EP*	T4477-3
MAX6962AMH	-40°C to +125°C	44 MQFP	—
MAX6962ATH	-40°C to +125°C	44 TQFN-EP*	T4477-3
MAX6963AMH	-40°C to +125°C	44 MQFP	—
MAX6963ATH	-40°C to +125°C	44 TQFN-EP*	T4477-3

*EP = Exposed paddle.



4-Wire Serially Interfaced 8 x 8 Matrix Graphic LED Drivers

ABSOLUTE MAXIMUM RATINGS

(Voltage with respect to GND.)

V+	-0.3V to +4V
All Other Pins	-0.3V to (V+ + 0.3V)
ROW1-ROW8 Sink Current	750mA
COL1-COL16 Source Current	48mA
Continuous Power Dissipation (T _A = +70°C)	
44-Pin MQFP	
(derate 12.7 mW/°C over +70°C)	1012mW
44-Pin TQFN	
(derate 27mW/°C over +70°C)	2162mW

Operating Temperature Range

(T _{MIN} to T _{MAX})	-40°C to +125°C
Junction Temperature	+150°C
Storage Temperature Range	-65°C to +150°C
Lead Temperature (soldering, 10s)	+300°C

Stresses beyond those listed under "Absolute Maximum Ratings" may cause permanent damage to the device. These are stress ratings only, and functional operation of the device at these or any other conditions beyond those indicated in the operational sections of the specifications is not implied. Exposure to absolute maximum rating conditions for extended periods may affect device reliability.

ELECTRICAL CHARACTERISTICS

(V+ = 2.7V to 3.6V, T_A = T_{MIN} to T_{MAX}, typical values at V+ = 3.3V, T_A = +25°C, unless otherwise noted.) (Note 1)

PARAMETER	SYMBOL	CONDITIONS		MIN	TYP	MAX	UNITS	
Operating Supply Voltage	V+			2.7		3.6	V	
Shutdown Supply Current	I _{SHDN}	Shutdown mode, all digital inputs at V+ or GND	T _A = +25°C		250	375	μA	
			T _A = T _{MIN} to +85°C			500		
			T _A = T _{MIN} to T _{MAX}			600		
Operating Supply Current	I+	Intensity set to full, no display load connected	T _A = +25°C		7.5	9	mA	
			T _A = T _{MIN} to +85°C			10		
			T _A = T _{MIN} to T _{MAX}			11		
Master Clock Frequency	f _{OSC}			1.0		8.5	MHz	
Dead-Clock Protection Frequency	f _{OSC}			50	90.5	200	kHz	
OSC High Time	t _{CH}			40			ns	
OSC Low Time	t _{CL}			40			ns	
Anode Column Source Current COL1-COL16	I _{SEG}	V _{LED} = 2.3V, V+ = 3.15V to 3.6V, current = high	T _A = +25°C		38	40	42	mA
			T _A = T _{MIN} to +85°C		37		43	
			T _A = T _{MIN} to T _{MAX}		37		44	
		V _{LED} = 2.3V, V+ = 2.7V to 3.6V, current = low	T _A = +25°C		19	20	21	
			T _A = T _{MIN} to +85°C		18.5		21.5	
			T _A = T _{MIN} to T _{MAX}		18.5		22.0	
Anode Column Source-Current Temperature Variation COL1-COL16	I _{TC}	V _{LED} = 2.3V, V+ = 3.15V to 3.6V, current = high			200		ppm/°C	
		V _{LED} = 2.2V, V+ = 2.7V to 3.3V, current = low			200			
Segment Current Slew Rate	ΔI _{SEG} /Δt	T _A = +25°C			30		mA/μs	

4-Wire Serially Interfaced 8 x 8 Matrix Graphic LED Drivers

MAX6960-MAX6963

ELECTRICAL CHARACTERISTICS (continued)

(V+ = 2.7V to 3.6V, T_A = T_{MIN} to T_{MAX}, typical values at V+ = 3.3V, T_A = +25°C, unless otherwise noted.) (Note 1)

PARAMETER	SYMBOL	CONDITIONS	MIN	TYP	MAX	UNITS
LOGIC INPUTS AND OUTPUTS						
Input Leakage Current DIN, CLK, $\overline{\text{CS}}$, OSC, ADDIN, ADDCLK, $\overline{\text{RST}}$	I _{IH} , I _{IL}		-100	5	+100	nA
Logic-High Input Voltage DIN, CLK, $\overline{\text{CS}}$, OSC, ADDIN, ADDCLK, $\overline{\text{RST}}$	V _{IHI}		0.7 x V+			V
Logic-Low Input Voltage DIN, CLK, $\overline{\text{CS}}$, OSC, ADDIN, ADDCLK, $\overline{\text{RST}}$	V _{ILO}				0.3 x V+	V
DOUT Output Rise and Fall Times	t _{FTDO}	C _{LOAD} = 100pF			10	ns
DOUT Output High Voltage	V _{OHDO}	I _{SOURCE} = 20mA	V+ - 0.3			V
DOUT Output Low Voltage	V _{OLDO}	I _{SINK} = 20mA			0.3	V
ADDOUT Output High Voltage	V _{OHADO}	I _{SOURCE} = 500μA	V+ - 0.3			V
ADDOUT Output Low Voltage	V _{OLADO}	I _{SINK} = 500μA			0.3	V
ADDCLK Output High Voltage	V _{OHACK}	I _{SOURCE} = 2.5mA	V+ - 0.3			V
ADDCLK Output Low Voltage	V _{OLACK}	I _{SINK} = 2.5mA			0.3	V
TIMING CHARACTERISTICS						
CLK Clock Period	t _{CP}		50			ns
CLK Pulse-Width High	t _{CH}		22			ns
CLK Pulse-Width Low	t _{CL}		22			ns
$\overline{\text{CS}}$ Fall to CLK Rise Setup Time	t _{CSS}		12.5			ns
CLK Rise to $\overline{\text{CS}}$ Rise Hold Time	t _{CSH}		0			ns
DIN Setup Time	t _{DS}		12.5			ns
DIN Hold Time	t _{DH}		10			ns
Output Data Propagation Delay	t _{DO}				22	ns
Minimum $\overline{\text{CS}}$ Pulse High	t _{CSW}		25			ns

Note 1: All parameters are tested at T_A = +25°C. Specifications over temperature are guaranteed by design.

4-Wire Serially Interfaced 8 x 8 Matrix Graphic LED Drivers

Typical Operating Characteristics

(T_A = +25°C, unless otherwise noted.)

OPERATING SUPPLY CURRENT vs. TEMPERATURE

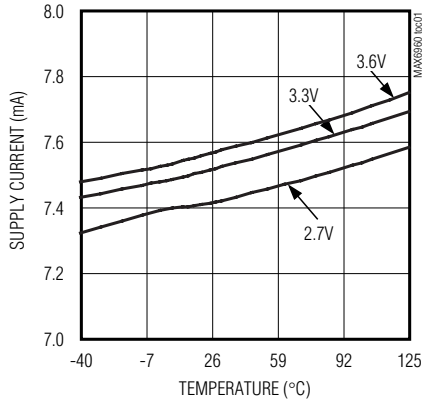

SHUTDOWN SUPPLY CURRENT vs. TEMPERATURE

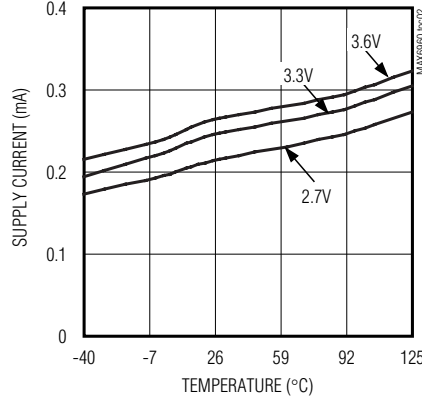

DEAD-CLOCK OSCILLATOR vs. SUPPLY VOLTAGE

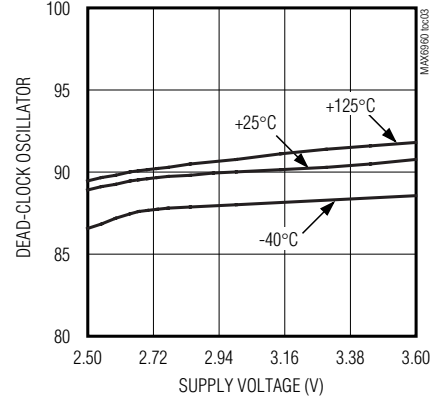

PEAK-OUTPUT SOURCE CURRENT vs. SUPPLY VOLTAGE (HIGH-CURRENT MODE) 2.3V LED

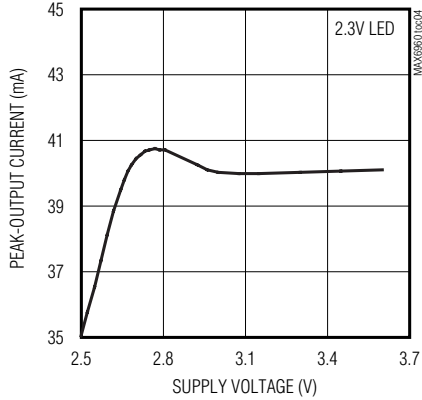

PEAK-OUTPUT SOURCE CURRENT vs. SUPPLY VOLTAGE (LOW-CURRENT MODE) 2.2V LED

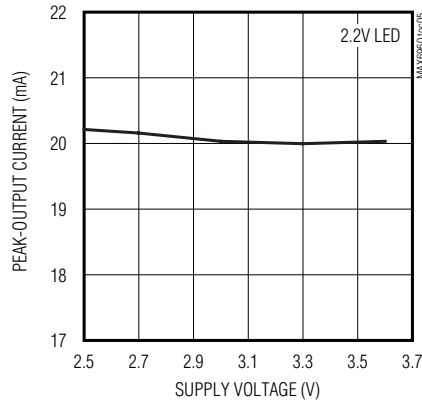

PEAK-OUTPUT SOURCE CURRENT vs. TEMPERATURE (HIGH-CURRENT MODE) 2.3V LED

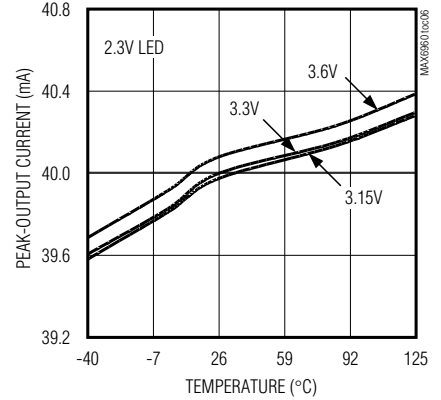

4-Wire Serially Interfaced 8 x 8 Matrix Graphic LED Drivers

Pin Description

MAX6960-MAX6963

PIN		NAME	FUNCTION
MQFP	TQFN		
1, 6, 11, 12, 44	1, 6, 11, 12, 44	GND	Ground
2-5, 7-10	2-5, 7-10	ROW1-ROW8	LED Cathode Drivers. ROW1 to ROW8 outputs sink current from the display's cathode rows.
13	13	OSC	Multiplex Clock Input. Drive OSC with a 1MHz to 8.5MHz CMOS clock.
14	14	\overline{CS}	Chip-Select Input. Serial data is loaded into the shift register when \overline{CS} is low. Data is loaded into the data latch on \overline{CS} 's rising edge.
15	15	DIN	Serial-Data Input. Data from DIN loads into the internal shift register on CLK's rising edge.
16	16	DOUT	Serial-Data Output. The output is tri-state.
17	17	CLK	Serial-Clock Input. On CLK's rising edge data shifts into the internal shift register.
18	18	\overline{RST}	Reset Input. Hold \overline{RST} low until at least 50ms after all interconnected MAX6960s are powered up.
19, 20, 21, 23-27, 29-33, 35, 36, 37	19, 20, 21, 23-27, 29-33, 35, 36, 37	COL1-COL16	LED Anode Drivers. COL1 to COL16 outputs source current into the display's anode columns.
22, 28, 34, 38	22, 28, 34, 38	V+	Positive Supply Voltage. Bypass V+ to GND with a single 47 μ F bulk capacitor per chip plus a 0.1 μ F ceramic capacitor per V+.
39	39	ADDOUT	Address-Data Output. Connect ADDOUT to ADDIN of the next MAX6960. Use ADDOUT of the last MAX6960 as a plane change interrupt output.
40	40	ADDIN	Address-Data Input. For first MAX6960, connect ADDIN to V+. For other MAX6960s, connect ADDIN to ADDOUT of the preceding MAX6960.
41	41	ADDCLK	Address-Clock Input/Output. Connect ADDCLK of all MAX6960 drivers together, ensuring that only one MAX6960's ADDIN input is connected to V+.
42	42	RISETO	Digit 0 Current Setting. Connect RISETO to GND to program all of digit 0's segment currents to 40mA. Leave RISETO open circuit to program all of digit 0's segment currents to 20mA. Connect RISETO to GND through a fixed or variable resistor to adjust all of digit 0's segment currents between 20mA and 40mA.
43	43	RISSET1	Digit 1 Current Setting. Connect RISSET1 to GND to program all of digit 1's segment currents to 40mA. Leave RISSET1 open circuit to program all of digit 1's segment currents to 20mA. Connect RISSET1 to GND through a fixed or variable resistor to adjust all of digit 1's segment currents between 20mA and 40mA.
—	EP	EP	Exposed Pad on Package Underside. Connect to GND.

4-Wire Serially Interfaced 8 x 8 Matrix Graphic LED Drivers

Table 1. Levels of Functionality

PART	AVAILABLE FUNCTIONS						REGISTER LIMITATIONS
	RGB 2 BITS PER PIXEL*	RGB 1 BIT PER PIXEL*	RGY 2 BITS PER PIXEL	RGY 1 BIT PER PIXEL	MONOCOLOR 2 BITS PER PIXEL	MONOCOLOR 1 BIT PER PIXEL	
MAX6960	√	√	√	√	√	√	None.
MAX6961	—	√	—	√	—	√	PI bit (bit D7) in global panel configuration register is fixed at 0 (Table 22).
MAX6962	√	√	—	—	√	√	C bit (bit D6) in global panel configuration register is fixed at 0 (Table 21).
MAX6963	—	√	—	—	—	√	C bit (bit D6) in global panel configuration register is fixed at 0 (Table 21). PI bit (bit D7) in global panel configuration register is fixed at 0 (Table 22).

*When operated per Figure 17.

Table 2. Maximum Display Matrix on a Single 4-Wire Interface

DISPLAY CONFIGURATION	MAXIMUM PIXEL COUNT	EXAMPLE MAXIMUM PANEL (PIXELS)
Monocolor	32,768	256 x 128
RGY	16,384	256 x 64
RGB	32,768 (3 buses required; see Figure 17)	128 x 85

Table 3. 4-Wire Interface Speed Requirements for Animation

DISPLAY-MEMORY-ACCESS METHOD	256 DRIVERS ON 4-WIRE INTERFACE, 50 FRAMES PER SECOND UPDATE RATE	
	1-BIT-PER-PIXEL INTENSITY CONTROL (Mbps)	2-BITS-PER-PIXEL INTENSITY CONTROL (Mbps)
8-bit indirect display memory addressing	1.64	3.28
24-bit direct display memory addressing	4.92	9.83

Quick-Start Guide

Selecting the Appropriate Driver

The MAX6960–MAX6963 matrix LED drivers are available in four versions, with different levels of functionality (Table 1). The two-part ID bits in the fault and device ID register (Table 32) identify the driver type to the interface software. The ID bits may be of use if the same panel software is used to drive more than one type of display panel, because the software can automatically detect the panel type.

This data sheet uses the generic name MAX6960 to refer to the family of four parts MAX6960 through MAX6963, unless there is a specific difference to discuss.

The purpose of this quick-start guide is to provide an overview of the capabilities of the MAX6960 so that the driver can be easily evaluated for a particular application, without fighting through a complex data sheet.

Terminology

- **Pixel:** One “point” on a display. Comprises one LED for a monochrome display, two LEDs for an RGY display, and three LEDs for an RGB display.
- **Monochrome:** Display has only one color, typically red for low-cost signs or orange for traffic signs. Varying the current through the LED changes the intensity of the red.

4-Wire Serially Interfaced 8 x 8 Matrix Graphic LED Drivers

- **Bicolor:** Literally means two color, and usually refers to LEDs built with two LED dice of different colors, typically red and green or red and orange/yellow.
- **Tricolor:** Literally means three color, and can refer to LEDs built with three LED dice of different colors, typically red, green, and blue. The term is also used to refer to a display built with bicolor LEDs, because there are three main colors available (red, green, yellow).
- **RGY:** Display uses one red LED (R) and one green LED (G) per pixel. When both red and green LEDs are lit, the resulting color is yellow (Y). Varying the current through the LEDs changes the intensity of the pixel and changes the color from red through shades of orange and yellow to green.
- **RGB:** Display uses one red LED (R), one green LED (G), and one blue LED (B) per pixel. Varying the current through the LEDs changes the intensity of the pixel and changes the color through many shades limited by the current control resolution.

MAX6960 Applications

The MAX6960 is a multiplexed, constant-current LED driver intended for high-efficiency indoor signage and message boards.

The high efficiency arises because the driver operates from a 3.3V nominal supply with minimal voltage headroom required across the driver output stages. The problem of removing heat from even a small display is therefore minimized.

The maximum peak LED drive current is 40mA, which when multiplexed eight ways, provides an average current of 5mA per LED. This current drive is expected to be adequate for indoor applications, but inadequate for outdoor signs operating in direct sun.

The MAX6960 directly drives monochrome (typically red or orange/yellow) or RGY (typically red/green or red/yellow) graphic displays using LEDs with a forward voltage drop up to 2.5V. Blue LEDs and some green LEDs cannot be driven directly because of their high forward voltage drop (around 3.5V to 4.5V). For these displays, the MAX6960 can be used as a graphic controller, just as it can be used for applications requiring higher peak segment currents, and in RGB panels needing a higher driver voltage for the blue LEDs. In these cases, the MAX6960 can be used with external drive transistors to control anode-row displays, with all driver features including pixel-level intensity control still available (see the *Applications Information* section and Figure 17).

Display Intensity Control

Five levels of intensity control are provided:

- A 256-step PWM panel intensity adjustment sets all MAX6960s simultaneously as a global panel brightness control (Table 27). The 256-step resolution is fine enough to allow fade-in/fade-out graphic effects, as well as provide a means for compensating a panel for background lighting.
- A 2-bits-per-pixel intensity control allows four brightness levels to be set independently per pixel. The pixel-level intensity control can be set to be either arithmetic (off, 1/3, 2/3, full) or geometric (off, 1/4, 1/2, full) for full flexibility (Table 24), and allows four colors to be displayed on monochrome panels, or 16 colors to be displayed on RGY panels, or 64 colors to be displayed on RGB panels.
- The LED drive current can be selected between either a 40mA peak per segment and a lower 20mA peak current on a digit-by-digit basis using the R_{ISSET0} and R_{ISSET1} pins. The lower (20mA) current may be the better choice to drive high-efficiency displays, and this setting allows the MAX6960 to operate from a supply voltage as low as 2.7V.
- The LED drive current can be adjusted between 40mA and 20mA peak current on a digit-by-digit basis using fixed or adjustable resistors connected from the R_{ISSET0} and R_{ISSET1} pins to GND. These controls enable **analog** relative adjustments in digit intensity, typically to calibrate digits from different batches, or to color balance RGY displays.
- The digit intensity controls allow each digit's operating current to be scaled down in 256 steps from the global panel intensity adjustment. The effective operating current for each digit becomes n/256th of the panel intensity value. These controls enable **digital** relative adjustments in digit intensity in addition to the analog approach outlined above.

Display Size Limitations

The maximum display size that can be handled by a single 4-wire serial interface is given in Table 2, which is for the maximum 256 interconnected MAX6960s. Larger display panels can be designed using a separate \overline{CS} line for each group of (up to) 256 MAX6960s. Each group would also have its own local 3-wire bus to allocate the driver addresses. The 4-wire interface speeds requirement when continuously updating display memory for high-speed animations is given in Table 3.

4-Wire Serially Interfaced 8 x 8 Matrix Graphic LED Drivers

Table 4. Standard Driver Connection to Monocolor and RGY 8 x 8 Displays

	DRIVER PINS ROW1-ROW8	DRIVER PINS COL1-COL8	DRIVER PINS COL9-COL16
Monocolor digit 0 (red*)	Digit 0 (red*) rows (cathodes) R1 to R8	Digit 0 columns (anodes) C1 to C8	—
Monocolor digit 1 (green*)	Digit 1 (green*) rows (cathodes) R1 to R8	—	Digit 1 columns (anodes) C1 to C8
RGY red/green	Red/green rows (cathodes) R1 to R8	Red columns (anodes) C1 to C8	Green columns (anodes) C1 to C8

*Digit 0 of a monicolor display is called red, and digit 1 is called green in the data sheet.

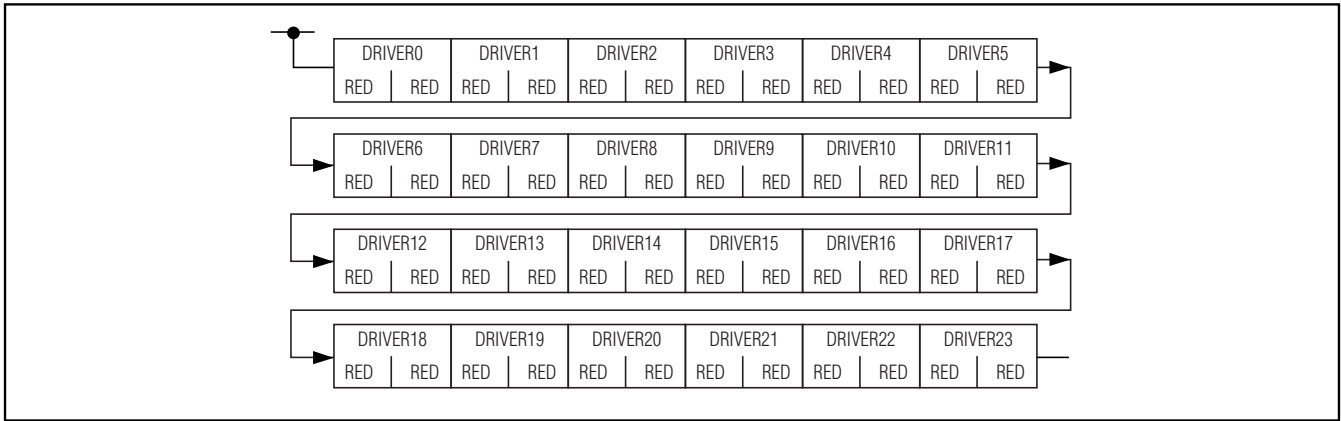

Figure 1. Monocolor 1-Bit-per-Pixel, 96-Pixel x 32-Pixel Display Example

Software Control

The hardware features are designed to simplify the software interface and eliminate software timing dependencies:

- Two or four planes of display memory are stored, allowing images to be preloaded into the MAX6960-MAX6963 frame memory.
- Animation timing is built in, sequencing through the two or four planes automatically. System software has to update the upcoming plane(s) with new data ahead of time, but do not be concerned about exact timing. The frame rate is adjustable to as fast as 63 frames a second for animations, or to as slow as one frame change every 63s for advertising sequencing.
- Multiple MAX6960s interconnect and share display memory so that the software “sees” the display as memory-mapped planes of contiguous RAM.
- Global commands that need to be received and acted on by every MAX6960 in a panel do just that, with one write.

Hardware Design

A MAX6960 normally drives an 8 x 16 LED matrix, comprising 8 cathode rows and 16 anode columns, or 8 anode rows and 16 cathode columns with external drivers.

The MAX6960 standard wiring connection to either two monicolor 8 x 8 digits, or to a single RGY 8 x 8 digit is shown in Table 4. Figure 3 shows the display pin naming. Figures 1 and 2 show example displays with the MAX6960 drivers connecting to monicolor and RGY panels. Figure 4 shows how the display memory maps to the physical pixels on the display panel, provided that the MAX6960 drivers are interconnected correctly in a raster-like manner from top left of the panel to bottom right.

Detailed Description

Overview

The MAX6960 is an LED display driver capable of driving either two monicolor 8 x 8 cathode-row matrix digits, or a single RGY 8 x 8 cathode-row matrix digit. The architecture of the driver is designed to allow a large graphic

4-Wire Serially Interfaced 8 x 8 Matrix Graphic LED Drivers

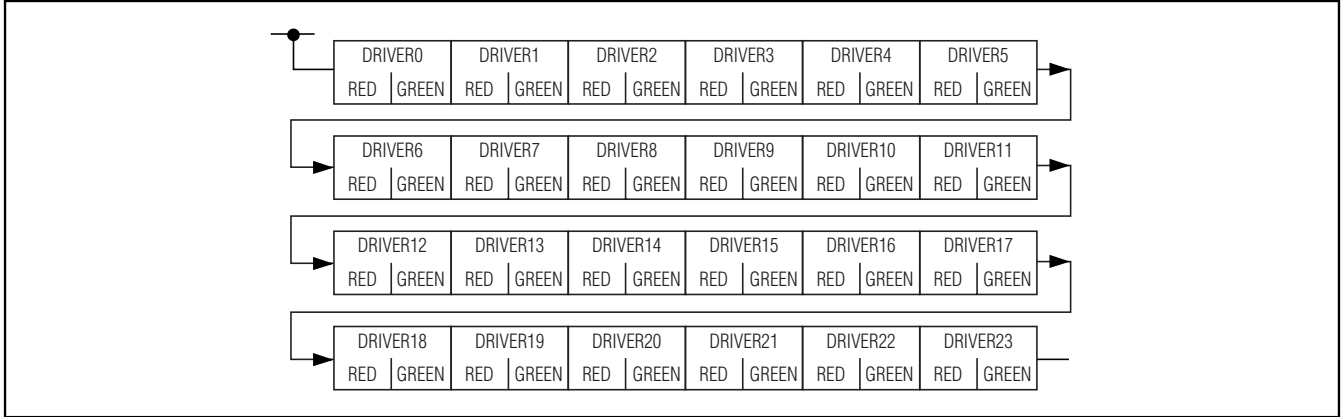

Figure 2. RGY 1-Bit-per-Pixel 48-Pixel x 32-Pixel Display Example

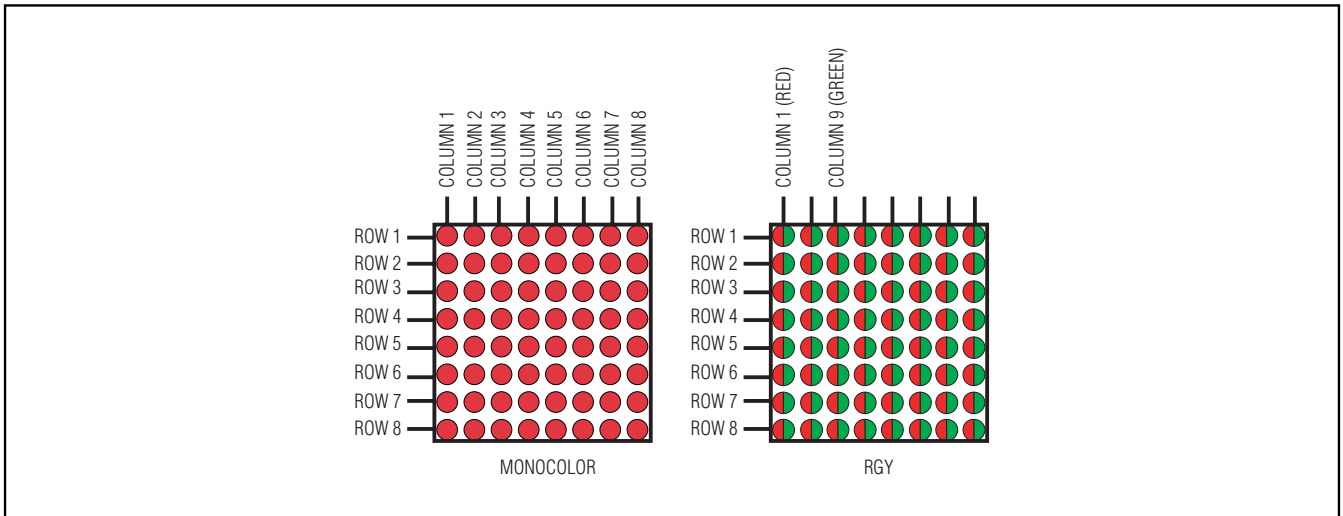

Figure 3. 8 x 8 Matrix Pin Assignment

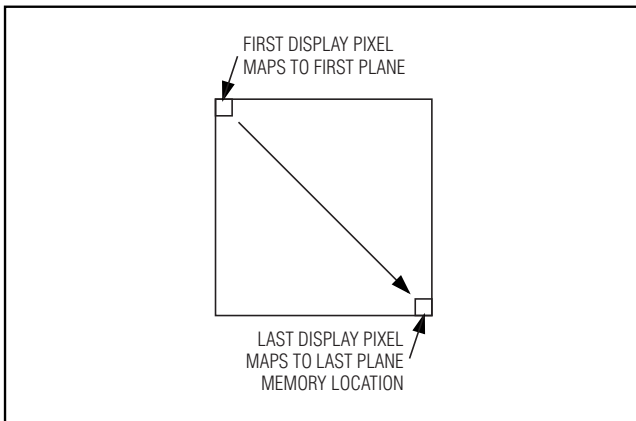

Figure 4. How Plane Memory Across Multiple MAX6960-MAX6963 Maps to Display Pixels

display panel to be driven easily and intuitively by multiple MAX6960s using 8 x 8 cathode-row matrix digits. The MAX6960s in a display-driver design not only share the host 4-wire interface, but they also share a local 3-wire interface that is not connected to the host. The local 3-wire interface works with the user's driver settings to configure all the MAX6960s to appear to the host interface as one contiguous memory-mapped driver.

The pixel level-intensity control uses frame modulation. Pixels are enabled and disabled on a frame-by-frame basis over a 12-frame super frame (Table 5). The effective pixel frame duty cycle within a super frame sets each pixel's effective intensity. The 12-frame period of a super frame allows arithmetic and geometric intensity scales to be mixed on the same driver. This allows the user to set up an RGY display with a different color scale for red and

4-Wire Serially Interfaced 8 x 8 Matrix Graphic LED Drivers

Table 5. Frame Modulation with Pixel Intensity

PIXEL GRADUATION	BIT	BIT	PIXEL INTENSITY SETTING	PATTERN OF MULTIPLEX CYCLES FOR WHICH A PIXEL IS ENABLED											
				0	1	2	3	4	5	6	7	8	9	10	11
Both	1	1	Full	1	1	1	1	1	1	1	1	1	1	1	1
Arithmetic	1	0	2/3	1	0	1	1	0	1	1	0	1	1	0	1
Geometric	1	0	1/2	1	0	1	0	1	0	1	0	1	0	1	0
Arithmetic	0	1	1/3	0	1	0	0	1	0	0	1	0	0	1	0
Geometric	0	1	1/4	0	1	0	0	0	1	0	0	0	1	0	0
Both	0	0	Off	0	0	0	0	0	0	0	0	0	0	0	0

Table 6. Panel Configuration

GLOBAL PANEL CONFIGURATION REGISTER		PIXEL-LEVEL INTENSITY CONTROL	DISPLAY TYPE	DISPLAY MAPPING ADDRESSES PER PLANE	DISPLAY PLANES AVAILABLE
PLANES/INTENSITY (PI BIT)	COLOR (C BIT)				
0	0	1 bit per pixel	Monocolor	16 red contiguous	4
0	1	1 bit per pixel	RGY	8 red contiguous, 8 green contiguous	4
1	0	2 bits per pixel	Monocolor	16 red contiguous, 16 green contiguous	2
1	1	2 bits per pixel	RGY	16 red (2 noncontiguous groups of 8), 16 green (2 noncontiguous groups of 8)	2

green. The MAX6960 uses display memory planes to store the display images. A memory plane is the exact amount of memory required to store the display image. The memory plane architecture allows one plane to be used to refresh the display, while at least one other plane is available to build up the next image. The global plane counter register (Table 30) allows the plane used to refresh the display to be selected either directly on command, or automatically under MAX6960 control. Automatic plane switching can be set from 63 plane changes a second to one plane change every 63s.

Display Memory Addressing

The MAX6960 contains 64 bytes of display mapping memory. This display memory provides four memory planes (of 16 bytes) when 1-bit-per-pixel intensity control is selected, or two memory planes (of 32 bytes) when 2-bits-per-pixel intensity control is used (Table 6). The 64 bytes of display memory in a MAX6960 could be accessed with 6 bits of addressing on a driver-by-driver basis.

The MAX6960 uses a 14-bit addressing scheme. The address map encompasses up to 256 MAX6960 drivers, all connected to the host through a common 4-wire interface, and also interconnected through a local 3-wire interface. The purpose of the 3-wire interface is to actively segment the 14-bit address space among the (up to) 256 MAX6960s.

The total display memory is already partitioned among these MAX6960 drivers in a register format. The MAX6960s repartition these registers to appear as contiguous planes of display memory, organized by color (red, then green) and then into planes (P0 to P4) (Table 6).

Register Addressing Modes

The MAX6960 accepts 8-bit, 16-bit, and 24-bit transmissions. All MAX6960s sharing an interface receive and decode all these transmissions, but the content of a transmission determines which MAX6960s store and use a particular transmission, and which discard it (Table 7).

4-Wire Serially Interfaced 8 x 8 Matrix Graphic LED Drivers

MAX6960-MAX6963

Table 7. Register Addressing Modes

DATA FORMAT	8-, 16-, OR 24-BIT DATA PACKET SENT TO MAX6960																								
	D23	D22	D21	D20	D19	D18	D17	D16	D15	D14	D13	D12	D11	D10	D9	D8	D7	D6	D5	D4	D3	D2	D1	D0	
8-bit indirect display memory addressing. Address is global display indirect address (14 bits) stored as {MSB, LSB} in {register 0x0A, register 0x09}.	—														8 bits of display memory										
16-bit device addressing.	—							R/W	AI	L/G	0	4-bit address				8 bits of driver register data									
Factory reserved; do not write to this address.	—											1	—												
24-bit direct display memory addressing (monocolor 1 bit per pixel).	R/W	X	Planes 0, 1, 2, 3			12-bit addressing across 256 drivers, 4096 x 8 red pixels							8 bits of display memory (1 bit per pixel)												
24-bit direct display memory addressing (RGY 1 bit per pixel).	R/W	X	Planes 0, 1, 2, 3			12-bit addressing across 256 drivers, 2048 x 8 red pixels, and 2048 x 8 green pixels							8 bits of display memory (1 bit per pixel)												
24-bit direct display memory addressing (monocolor 2 bits per pixel).	R/W	X	Planes 0, 1			13-bit addressing across 256 drivers, 4096 x 4 red pixels							8 bits of display memory (2 bits per pixel)												
24-bit direct display memory addressing (RGY 2 bits per pixel).	R/W	X	Planes 0, 1			13-bit addressing across 256 drivers, 4096 x 4 red pixels, and 4096 x 4 green pixels							8 bits of display memory (2 bits per pixel)												

8-Bit Transmissions

Eight-bit transmissions are write-only, data-only accesses that write data to the display memory indirected by the global display indirect address register (Figure 6). The global display indirect address register autoincrements after the write access. Eight-bit transmissions provide the quickest method of updating a plane of display memory of the MAX6960. It is the most suitable display update method if the host system builds an image in local memory, and then dumps the image into a display plane of the MAX6960.

16-Bit Transmissions

Sixteen-bit transmissions are read/write, command-and-data accesses to the MAX6960's configuration registers (Figure 7). A write can generally be global (updates all MAX6960s on the 4-wire bus with the same

data) or specific (updates just the MAX6960 indirected by the global driver indirect address register). **Note: The global driver indirect address register selects a specific MAX6960. This is not the same as the global display indirect address register, which points to display memory that could be in any MAX6960.** A 16-bit read is always indirected through the global driver indirect address register to select only one MAX6960 to respond. When a read or write is indirected through the global driver indirect address register, the 16-bit command can choose whether the global driver indirect address is autoincremented after the command has been executed. This allows the host to set up one or more registers in consecutive MAX6960s with the display indirect address, autoincrementing only when required.

4-Wire Serially Interfaced 8 x 8 Matrix Graphic LED Drivers

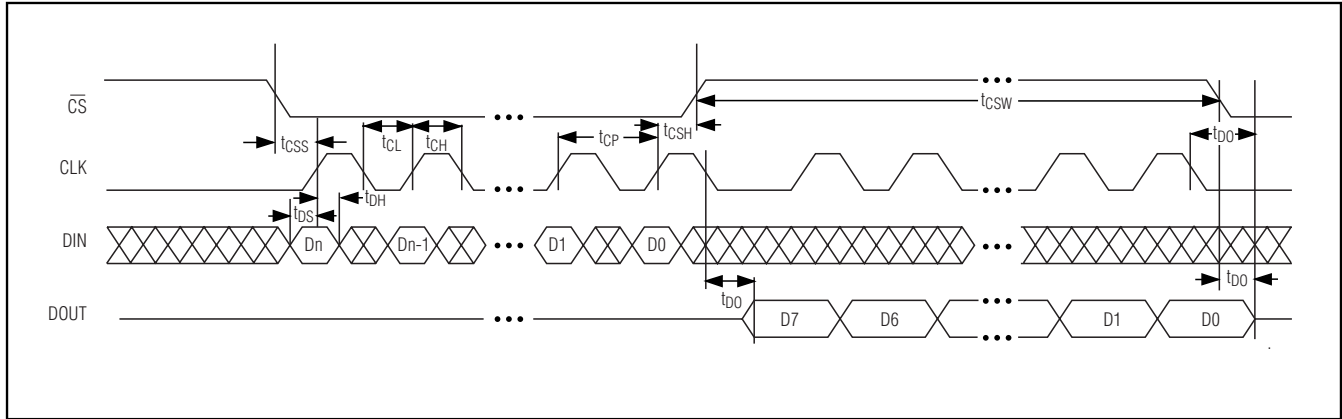

Figure 5. Timing Diagram

24-Bit Transmissions

Twenty-four-bit transmissions are read/write, address-and-data accesses to the MAX6960's display memory (Figure 8). This is direct access to display memory because the memory address is included in the 24-bit transmission, compared with an 8-bit transmission, which uses the memory address stored in the global display indirect address register. Twenty-four-bit transmissions provide the random-access method of updating a plane of display memory of the MAX6960. It is the most suitable display update method if the host system builds an image directly in a display memory plane, rather than in host local memory.

Host 4-Wire Serial Interface

Serial Addressing

The MAX6960 communicates to the host through a 4-wire serial interface. The interface has three inputs: clock (CLK), chip select (\overline{CS}), and data in (DIN), and one output, data out (DOUT). \overline{CS} must be low to clock data into the device, and DIN must be stable when sampled on the rising edge of CLK. DOUT is used for read access, and is stable on the rising edge of CLK. DOUT is high impedance except during MAX6960 read accesses. Multiple MAX6960s may be connected to the same 4-wire interface, with all devices connected to all four interface lines in parallel. The normal limit of paralleled MAX6960s is 256, because that is the interconnection limit for the 3-wire interface and associated device addressing. The *Applications Information* section discusses some practical issues raised by driving many devices in parallel from the same interface.

The serial interface responds to only 8-bit, 16-bit, and 24-bit commands (Table 7).

The MAX6960 ignores any transmission that is not exactly 8 bits, 16 bits, or 24 bits between the falling and subsequent rising edge of \overline{CS} .

Control and Operation Using the 4-Wire Interface

Controlling the MAX6960 requires sending an 8-bit, 16-bit, or 24-bit word. The last byte, D7 through D0, is always the data byte. Eight-bit accesses are write-only accesses; 16-bit or 24-bit accesses are read or write accesses, as determined by the MSB of the transmission, which is set for a read access; clear for a write. A 16-bit or 24-bit read involves transmitting 16 or 24 bits to DIN, taking \overline{CS} high, and then reading back 8 bits from DOUT. Only one MAX6960's DOUT is enabled from tri-state for readback. The selected MAX6960's DOUT normally returns to tri-state after the 8th falling edge of CLK. However if \overline{CS} falls during the read before the 8th falling edge of CLK, then the readback is terminated and the selected MAX6960's DOUT returns to tri-state.

If a number of bits other than exactly 8 bits, 16 bits, or 24 bits are clocked into the MAX6960 between taking \overline{CS} low and taking \overline{CS} high again, then that transmission is ignored.

Writing Device Registers

The MAX6960 is written to using the following sequence (Figures 3, 4, and 5):

- 1) Take CLK low.
- 2) Take \overline{CS} low.
- 3) For an 8-bit transmission:
 - Clock 8 bits of data into DIN, D7 first to D0 last, observing the setup and hold times.
- For a 16-bit transmission:
 - Clock 16 bits of data into DIN, D15 first to D0 last,

4-Wire Serially Interfaced 8 x 8 Matrix Graphic LED Drivers

MAX6960-MAX6963

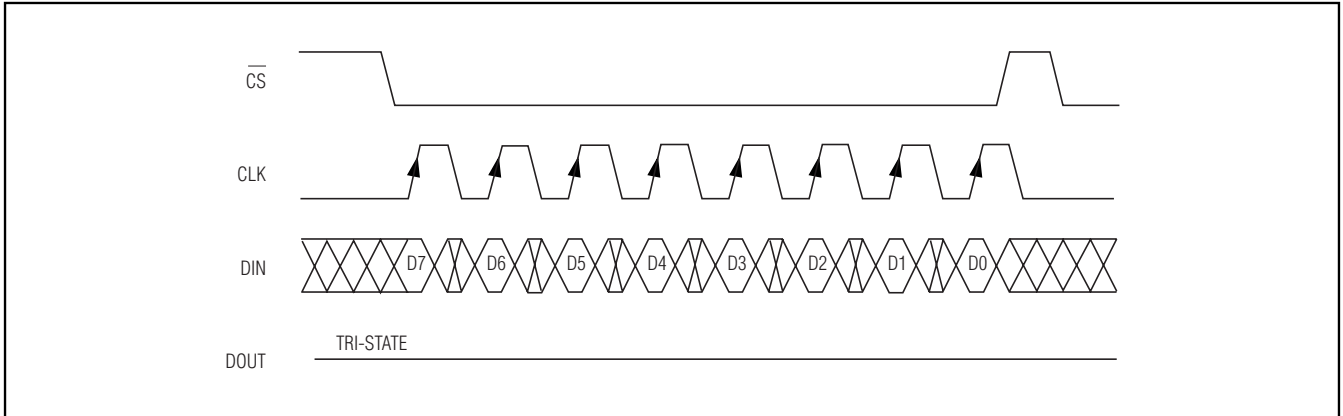

Figure 6. 8-Bit Write to the MAX6960-MAX6963

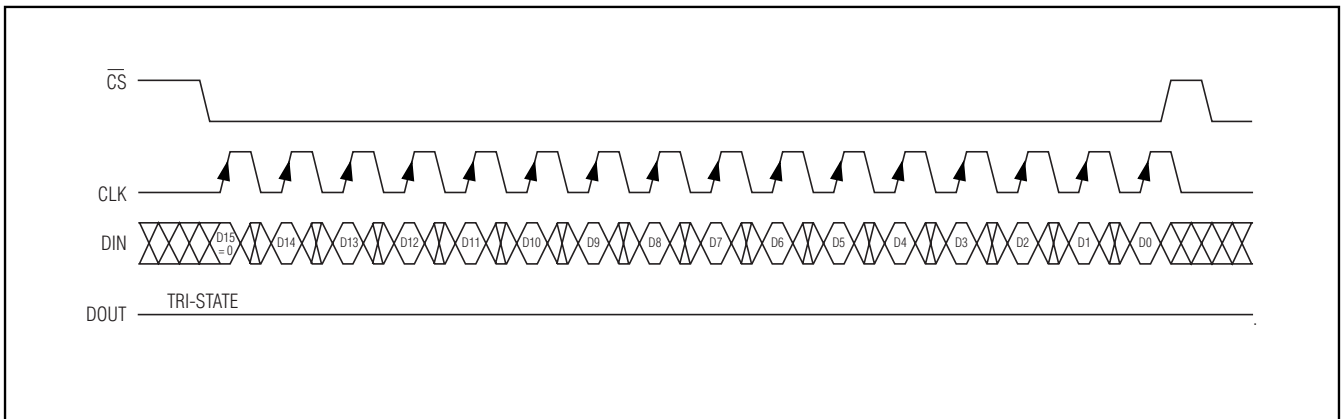

Figure 7. 16-Bit Write to the MAX6960-MAX6963

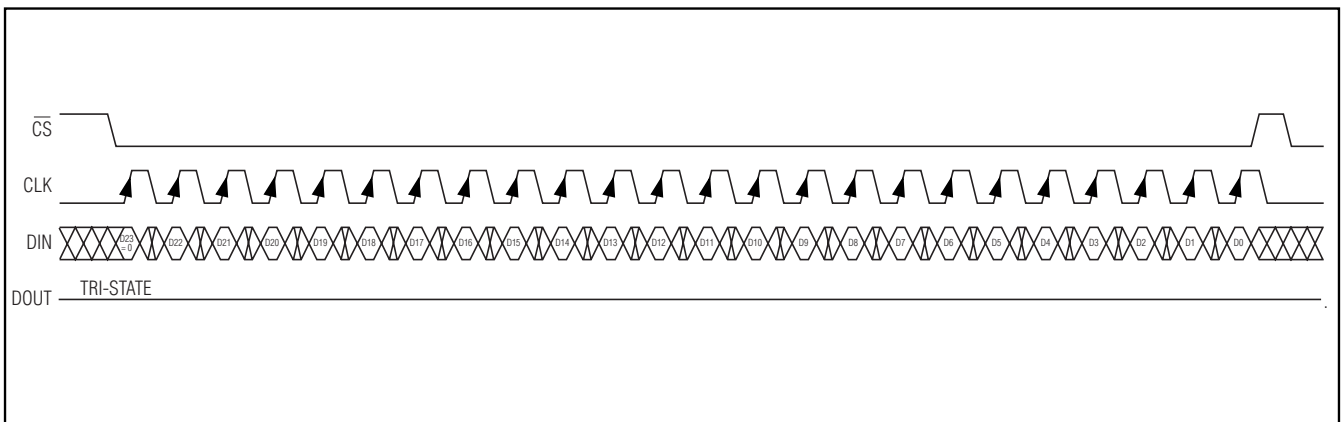

Figure 8. 24-Bit Write to the MAX6960-MAX6963

4-Wire Serially Interfaced 8 x 8 Matrix Graphic LED Drivers

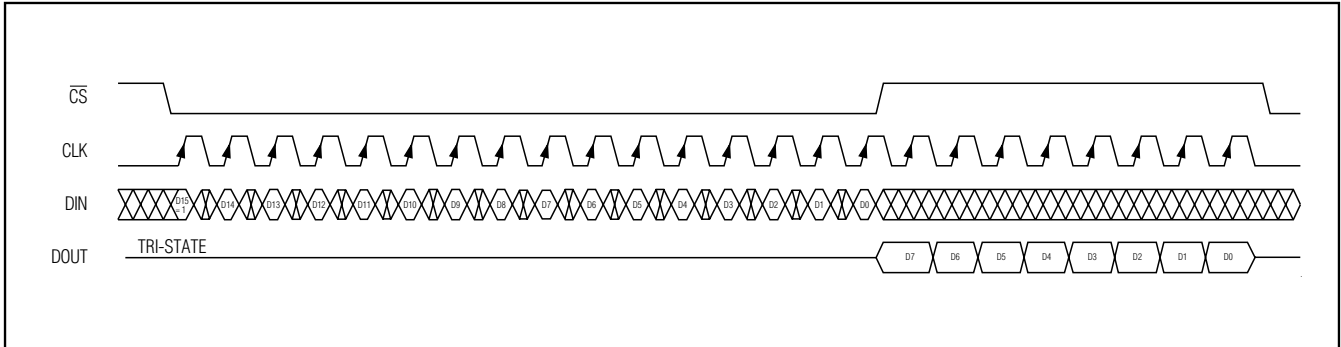

Figure 9. 16-Bit Read from the MAX6960-MAX6963

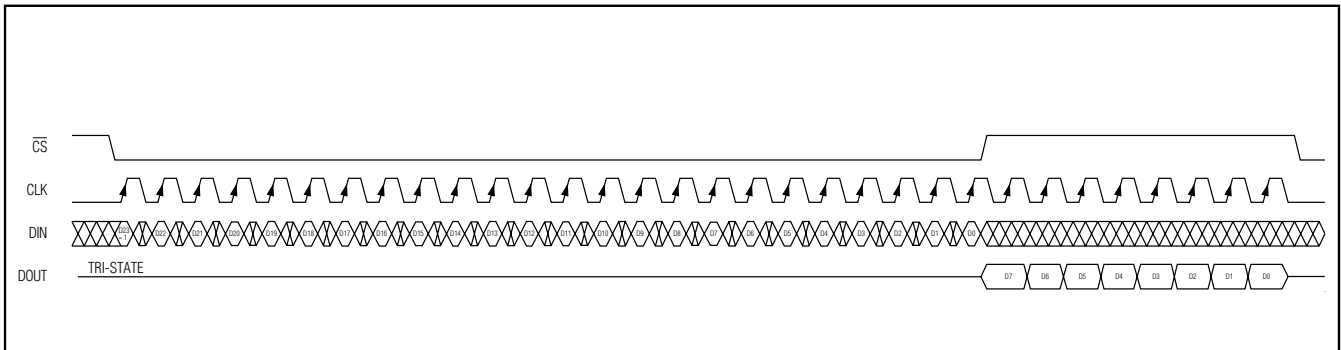

Figure 10. 24-Bit Read from the MAX6960-MAX6963

observing the setup and hold times. Bit D15 is low, indicating a write command.

For a 24-bit transmission:

Clock 24 bits of data into DIN, D23 first to D0 last, observing the setup and hold times. Bit D23 is low, indicating a write command.

- 4) Take \overline{CS} high (while CLK is still high after clocking in the last data bit).
- 5) Take CLK low.

Reading Device Registers

Any register data within the MAX6960 may be read by sending a logic-high to bit D15. The sequence is:

- 1) Take CLK low.
- 2) Take \overline{CS} low.
- 3) For a 16-bit transmission:

Clock 16 bits of data into DIN, D15 first to D0 last, observing the setup and hold times. Bit D15 is high, indicating a read command. Bits D7 to D0 are dummy bits, and are discarded by the MAX6960.

For a 24-bit transmission: Clock 24 bits of data into DIN, D23 first to D0 last, observing the setup and

hold times. Bit D23 is high, indicating a read command. Bits D7 to D0 are dummy bits, and are discarded by the MAX6960.

- 4) Take \overline{CS} high (while CLK is still high after clocking in the last data bit).
- 5) Take CLK low.
- 6) The selected MAX6960's DOUT is enabled from tri-state for read back.
- 7) Clock 8 bits of data from DOUT, D7 first to D0 last, observing the setup and hold times.
- 8) Take CLK low after the final (8th) data bit.

The selected MAX6960's DOUT returns to tri-state.

Figure 10 shows a read operation when 24 bits are transmitted and 8 bits are read back.

Local 3-Wire Serial Interface

The MAX6960 uses a 3-wire interface to bus together up to 256 MAX6960s. The 3-wire bus enables each device to calculate its own unique driver address (0 to 255), and reconfigure its display memory. The ADDOUT output also provides an interrupt at every page change, when the plane counter is configured to automatic (Table 30).

4-Wire Serially Interfaced 8 x 8 Matrix Graphic LED Drivers

3-Wire Interface Data Lines (ADDOUT and ADDIN)

One MAX6960 is designated the master device, and this is allocated driver address 0. The master's ADDIN pin is connected to V+, identifying it as the first device. **This first MAX6960 should be the driver for the top-left pixels of the display panel.** The master's ADDOUT pin is connected to the second MAX6960's ADDIN pin, and that MAX6960's ADDOUT pin is connected to the third MAX6960's ADDIN, and so on up to 256 MAX6960s. The last MAX6960's ADDOUT pin is left open circuit. **The last MAX6960 should be the driver for the bottom-right pixels of the display panel.** The ADDOUT is initialized low at the start of a 3-wire interface configuration operation, and goes high (N + 1.5) ADDCLK periods later, where n is the driver address of the MAX6960 (0 to 255). See Figures 1 and 2 for connection examples.

3-Wire Interface Clock (ADDCLK)

The ADDCLK pins for all MAX6960s are all connected together. ADDCLK data rate is determined by OSC / 4, nominally 1.048576 MHz. The ADDCLK pin for the master MAX6960 (driver address 0) is always an output, and all the other ADDCLKs are always inputs. ADDCLK is active for exactly 256 clock cycles when a panel configuration is being performed (on power-up reset, and after a write to the global panel configuration register).

Use of ADDOUT as Plane Change Interrupt (IRQ)

When the plane counter is configured to automatic mode (bit 6 of the global plane counter register is set) (Table 30), ADDOUT pulses low for a time of 512/OSC (nominally 122µs) at the start of every automatic plane change. This signal can be used as an interrupt output from the display panel to the host to flag that the previous display plane is now unused and can be written with a new image.

Multiplex Clock

The OSC input for all MAX6960s sharing a 3-wire interface bus (but not necessarily a 4-wire interface bus) should be driven by a common CMOS-level clock ranging between 1MHz and 8.5MHz. It is usually necessary to use an external clock tree to fan out multiple clock drives when larger numbers of MAX6960s are used because of the capacitive loads. For example, each one of the eight outputs of a standard 74HC541 octal buffer could drive 8 to 32 MAX6960 OSC inputs, depending on the layout used.

The recommended setting for OSC is 4.194303MHz. This frequency sets the slow global plane counter resolution to 1s, and the fast global plane counter resolution to 1Hz.

Table 8. Register Address Map

REGISTER	COMMAND ADDRESS								HEX CODE	
	D15	D14	D13	D12	D11	D10	D9	D8		
Driver Address (read only)	X			X	0	0	0	0	0x00	
Pixel Intensity Scale	R/W	Autoincrement	Local/Global	X	0	0	0	1	0x01	
Panel Intensity				X	0	0	1	0	0x02	
Digit 0 Intensity				X	0	0	1	1	0x03	
Digit 1 Intensity				X	0	1	0	0	0x04	
Fault				X	0	1	0	1	0x05	
—				X	0	1	1	0	0x06	
—				X	0	1	1	1	0x07	
Global Driver Indirect Address*				X	X	X	1	0	0	0
Global Display Indirect Address LSB*		X	X	X	1	0	0	1	0x09	
Global Display Indirect Address		X	X	X	1	0	1	0	0x0A	
Global Plane Counter*		X	X	X	1	0	1	1	0x0B	
Global Clear Planes*		X	X	X	1	1	0	0	0x0C	
Global Panel Configuration*		X	X	X	1	1	0	1	0x0D	
Global Driver Devices*		X	X	X	1	1	1	0	0x0E	
Global Driver Rows*			X	X	X	1	1	1	1	0x0F

*When reading from the global registers, only the master MAX6960 (whose driver address is 0x00) responds.

4-Wire Serially Interfaced 8 x 8 Matrix Graphic LED Drivers

Table 9. Register Address Local/Global Control Bit Format

REGISTER	ADDRESS CODE (HEX)	COMMAND ADDRESS							
		D15	D14	D13	D12	D11	D10	D9	D8
LOCAL: Only the MAX6960 indirected by driver indirect address is written.	0x00 to 0x07	0	X	0	X	X	X	X	X
GLOBAL: All MAX6960s are written with the same data.		0	X	1	X	X	X	X	X
LOCAL: The MAX6960 indirected by driver indirect address responds.		1	X	0	X	X	X	X	X
GLOBAL: The MAX6960 configured to address 0x00 responds.		1	X	1	X	X	X	X	X
GLOBAL: All MAX6960s are written with the same data.	0x08 to 0x0F	0	X	X	X	X	X	X	X
GLOBAL: The MAX6960 configured to address 0x00 responds.		1	X	X	X	X	X	X	X

Table 10. Register Address Autoincrement Control Bit Format

REGISTER	ADDRESS CODE (HEX)	COMMAND ADDRESS							
		D15	D14	D13	D12	D11	D10	D9	D8
Driver indirect address is not changed	0x00 to 0x07	X	0	X	X	X	X	X	X
Driver indirect address is incremented after read/write		X	1	X	X	X	X	X	X
Driver indirect address is not changed	0x08 to	X	X	X	X	X	X	X	X

Table 11. Driver Address Register Format

REGISTER	ADDRESS CODE (HEX)	REGISTER DATA							
		D7	D6	D5	D4	D3	D2	D1	D0
Driver address	0x00	MSB	8-bit driver address 0x00 to 0xFF						LSB

Global and Local Register Addressing

The register map (Table 8) contains three local registers and eight global registers. Global registers are always written to in all MAX6960s (on the same 4-wire interface) at the same time, using a 16-bit transmission. A read from a global register also always results in a read from driver address 0. The global nature of these registers ensures that all drivers work together, and there is no chance of a software miss-send causing, for example, multiple MAX6960s to try to transmit on the 4-wire DOUT line at the same time.

The three local registers can be written to on an individ-

ual basis (updates just the MAX6960 indirected by the global driver indirect address register), or on a global basis (updates all MAX6960s), according to the status of the local/global bit (Table 9). The local/global bit is ignored during a 16-bit read transmission, and the MAX6960 pointed to by the global driver indirect address register is read.

Register Address Autoincrementing

When a read or write is indirected through the global driver indirect address register, the 16-bit command can choose whether the global driver indirect address is autoincremented after the command has been executed.

4-Wire Serially Interfaced 8 x 8 Matrix Graphic LED Drivers

MAX6960-MAX6963

Table 12. Power-Up Configuration

REGISTER FUNCTION	POWER-UP CONDITION	ADDRESS CODE (HEX)	REGISTER DATA							
			D7	D6	D5	D4	D3	D2	D1	D0
Driver address (read only)	Address 0	0x00	0	0	0	0	0	0	0	0
Pixel intensity scale	Arithmetic for red and green	0x01	X	X	X	X	X	X	0	0
Panel intensity	128/256 intensity	0x02	1	0	0	0	0	0	0	0
Digit 0 intensity	Full 255/256	0x03	1	1	1	1	1	1	1	1
Digit 1 intensity	Full 255/256	0x04	1	1	1	1	1	1	1	1
Fault	No faults	0x05	0	X	X	X	X	X	0	0
Global driver indirect address	Address 0x00	0x08	0	0	0	0	0	0	0	0
Global display indirect address LSB	Address 0x0000	0x09	0	0	0	0	0	0	0	0
Global display indirect address MSB		0x0A	X	X	0	0	0	0	0	0
Global plane counter	Manual selection to plane 0	0x0B	0	0	0	0	0	0	0	0
Global panel configuration	Shutdown mode, ripple sync enabled, mux flip enabled, color is mono, 4 display planes/1 bit per pixel	0x0D	0	0	1	1	X	X	X	0
Global driver devices	256 drivers interconnected	0x0E	1	1	1	1	1	1	1	1
Global driver rows	256 drivers in a row	0x0F	1	1	1	1	1	1	1	1

*When reading from the global registers, only the master MAX6960 (whose driver address is 0x00) responds.

Table 13. Global Driver Devices Format

REGISTER	ADDRESS CODE (HEX)	REGISTER DATA								
		D7	D6	D5	D4	D3	D2	D1	D0	
Global driver devices	0x0E	MS	8-bit global driver devices 0x00 to 0xFF							LSB

Table 14. Global Driver Rows Format

REGISTER	ADDRESS CODE (HEX)	REGISTER DATA								
		D7	D6	D5	D4	D3	D2	D1	D0	
Global driver rows	0x0F	MSB	8-bit global driver rows 0x00 to 0xFF							LSB

This allows the host to set up one or more registers in consecutive MAX6960s with the display indirect address, autoincrementing only when required (Table 10).

Driver Address Register

Reading the driver address register (Table 11) returns the driver address that has been assigned to a particular MAX6960. The order of the driver addresses is

determined purely by the order that the 3-wire interface is daisy-chained through multiple MAX6960s. The register is used to detect the presence of a MAX6960 at an address, and a binary search on the 256 possible addresses can be used to determine the size of an array of MAX6960s.

4-Wire Serially Interfaced 8 x 8 Matrix Graphic LED Drivers

Table 15. Global Panel Configuration Register Format

REGISTER	ADDRESS CODE (HEX)	REGISTER DATA							
		D7	D6	D5	D4	D3	D2	D1	D0
Global panel configuration	0x0D	PI	C	F	R	DP1	DP0	IP	S

Table 16. Global Panel Configuration—Shutdown Control (S Data Bit D0) Format

REGISTER	ADDRESS CODE (HEX)	REGISTER DATA							
		D7	D6	D5	D4	D3	D2	D1	D0
Shutdown	0x0D	PI	C	F	R	DP1	DP0	IP	0
Normal operation	0x0D	PI	C	F	R	DP1	DP0	IP	1

Table 17. Global Panel Configuration—Invert Pixels (IP Data Bit D1) Format

REGISTER	ADDRESS CODE (HEX)	REGISTER DATA							
		D7	D6	D5	D4	D3	D2	D1	D0
Logic 1 in display memory lights the appropriate LED (normal logic)	0x0D	PI	C	F	R	DP1	DP0	0	S
Logic 0 in display memory lights the appropriate LED (invert logic)	0x0D	PI	C	F	R	DP1	DP0	1	S

Table 18. Global Panel Configuration—Current Plane (DP0, DP1 Data Bit D2, D3) Format

REGISTER	ADDRESS CODE (HEX)	REGISTER DATA							
		D7	D6	D5	D4	D3	D2	D1	D0
Current display plane is P0	0x0D	PI	C	F	R	0	0	IP	S
Current display plane is P1	0x0D	PI	C	F	R	0	1	IP	S
Current display plane is P2	0x0D	0	C	F	R	1	0	IP	S
Current display plane is P0	0x0D	1	C	F	R	1	0	IP	S
Current display plane is P3	0x0D	0	C	F	R	1	1	IP	S
Current display plane is P1	0x0D	1	C	F	R	1	1	IP	S

Initial Power-Up

The power-up sequence consists of an internal power-on reset (POR), assertion of the external reset input \overline{RST} , and auto-address configuration (see the *Local 3-Wire Interface* section). The internal POR resets all control registers to the default values shown in Table 12. After \overline{RST} goes high an internal timer delays execution of the auto-address configuration for 2^{21} (2,097,152) OSC cycles (nominally 250ms at OSC = 4.194MHz) (see the *3-Wire Interface Clock (ADDCLK)* section). During this delay time, the global driver devices register (0x0E), global driver rows register (0x0F), and global panel configuration register (0x0D) should be written as these

values are used in the auto-address configuration sequence (see the *Device Configuration* section). After the internal delay time, the auto-addressing configuration commences and takes a fixed interval of 256 ADDCLK cycles to complete where the ADDCLK frequency is OSC/4 (see the *3-Wire Interface Clock (ADDCLK)* section). After completing the auto-self-addressing of all possible 256 interconnected devices, all of the MAX6960s enter shutdown mode.

All registers are capable of write device register operations during the internal delay interval using the 4-wire serial interface. Read device register operations are not allowed during auto-address configuration.

4-Wire Serially Interfaced 8 x 8 Matrix Graphic LED Drivers

Table 19. Global Panel Configuration—Ripple Sync Control (R Data Bit D4) Format

REGISTER	ADDRESS CODE (HEX)	REGISTER DATA							
		D7	D6	D5	D4	D3	D2	D1	D0
Ripple sync is disabled; all interconnected MAX6960s on the same 4-wire bus resynchronize together.	0x0D	PI	C	F	0	DP1	DP0	IP	S
Ripple sync is enabled; all interconnected MAX6960s on the same 4-wire bus resynchronize with a 0.9537µs delay between adjacent devices.	0x0D	PI	C	F	1	DP1	DP0	IP	S

Table 20. Global Panel Configuration—Mux Flip Control (F Data Bit D5) Format

REGISTER	ADDRESS CODE (HEX)	REGISTER DATA							
		D7	D6	D5	D4	D3	D2	D1	D0
Mux flip is disabled: all interconnected MAX6960s on the same 3-wire bus resynchronize to the multiplex timing shown in Figure 11.	0x0D	PI	C	0	R	DP1	DP0	IP	S
Mux flip is enabled: all interconnected MAX6960s on the same 3-wire bus resynchronize with MAX6960s with even driver addresses (0, 2, 4 to 254) operating to the multiplex timing shown in Figure 11, and MAX6960s with odd driver addresses (1, 3, 5 to 255) operating to the flipped multiplex timing shown in Figure 12.	0x0D	PI	C	1	R	DP1	DP0	IP	S

Device Configuration

The MAX6960s driving a display panel must be configured before the panel can be used to display images. The configuration involves the global panel configuration register (Table 15–Table 22), the global driver devices register (Table 13), and the global driver rows register (Table 14). The global driver devices register should be written with the total number of MAX6960s interconnected on the 3-wire interface, minus 1 (Table 13). For the four panel examples shown in Figures 1 and 2, 24 MAX6960s are used, so the global driver devices register should be written with the value 23, or 0x17.

The global driver rows register should be written with the number of MAX6960s per panel row, minus 1 (Table 14). For the panel examples shown in Figure 1 and Figure 2, there are six MAX6960s per row, so the global driver rows register should be written with the value 5.

The values stored in the global driver devices register and the global driver rows register, together with the C and PI bits in the global panel configuration register (Tables 21 and 22), are used by the 3-wire interface

configuration engine to reconfigure display memory addressing among the interconnected MAX6960s.

Global Panel Configuration Register

The global panel configuration register contains eight device settings (Table 15 to Table 22).

Shutdown Mode (Bit D0)

Shutdown mode is exited by clearing the S bit in the global panel configuration register (Table 16). When the MAX6960 is in shutdown mode, LED driver outputs ROW1–ROW8 and COL1–COL16 are tri-stated, and multiplexing is halted. Data in the global configuration registers remains unaltered. For minimum supply current in shutdown mode, logic inputs should be at GND or V+ potential. Shutdown mode is exited by setting the S bit in the global panel configuration register.

Invert Pixels (Bit D1)

The invert pixels (IP) bit in the global panel configuration register controls whether the display memory is used directly or inverted (Table 17).

4-Wire Serially Interfaced 8 x 8 Matrix Graphic LED Drivers

Table 21. Global Panel Configuration—Color Control (C Data Bit D6) Format

REGISTER	ADDRESS CODE (HEX)	REGISTER DATA							
		D7	D6	D5	D4	D3	D2	D1	D0
Display panel is built with monicolor or RGB digits (permanently set this way for MAX6962 and MAX6963)	0x0D	PI	0	F	R	DP1	DP0	IP	S
Display panel is built with RGY digits	0x0D	PI	1	F	R	DP1	DP0	IP	S

Table 22. Global Panel Configuration—Planes/Intensity Control (PI Data Bit D7) Format

REGISTER	ADDRESS CODE (HEX)	REGISTER DATA							
		D7	D6	D5	D4	D3	D2	D1	D0
Four display memory planes (0, 1, 2, 3) available; pixel level-intensity control is 1 bit per pixel per color (on/off) (permanently set this way for MAX6961 and MAX6963)	0x0D	0	C	F	R	DP1	DP0	IP	S
Two display memory planes (0, 1) available; pixel level-intensity control is 2 bits per pixel per color (4 levels)	0x0D	1	C	F	R	DP1	DP0	IP	S

Table 23. Frame Modulation with Pixel Intensity

PIXEL GRADUATION	PIXEL DATA		PIXEL INTENSITY SETTING	PATTERN OF MULTIPLEX CYCLES FOR WHICH A PIXEL IS ENABLED											
				0	1	2	3	4	5	6	7	8	9	10	11
Both	1	1	Full	1	1	1	1	1	1	1	1	1	1	1	1
Arithmetic	1	0	2/3	1	0	1	1	0	1	1	0	1	1	0	1
Geometric	1	0	1/2	1	0	1	0	1	0	1	0	1	0	1	0
Arithmetic	0	1	1/3	0	1	0	0	1	0	0	1	0	0	1	0
Geometric	0	1	1/4	0	1	0	0	0	1	0	0	0	1	0	0
Both	0	0	Off	0	0	0	0	0	0	0	0	0	0	0	0

Table 24. Pixel Intensity Scale Register Format

PIXEL GRADUATION	PIXEL DATA		PIXEL INTENSITY SETTING	PATTERN OF MULTIPLEX CYCLES FOR WHICH A PIXEL IS ENABLED											
				0	1	2	3	4	5	6	7	8	9	10	11
Both	1	1	Full	1	1	1	1	1	1	1	1	1	1	1	1
Arithmetic	1	0	2/3	1	0	1	1	0	1	1	0	1	1	0	1
Geometric	1	0	1/2	1	0	1	0	1	0	1	0	1	0	1	0
Arithmetic	0	1	1/3	0	1	0	0	1	0	0	1	0	0	1	0
Geometric	0	1	1/4	0	1	0	0	0	1	0	0	0	1	0	0
Both	0	0	Off	0	0	0	0	0	0	0	0	0	0	0	0

4-Wire Serially Interfaced 8 x 8 Matrix Graphic LED Drivers

MAX6960-MAX6963

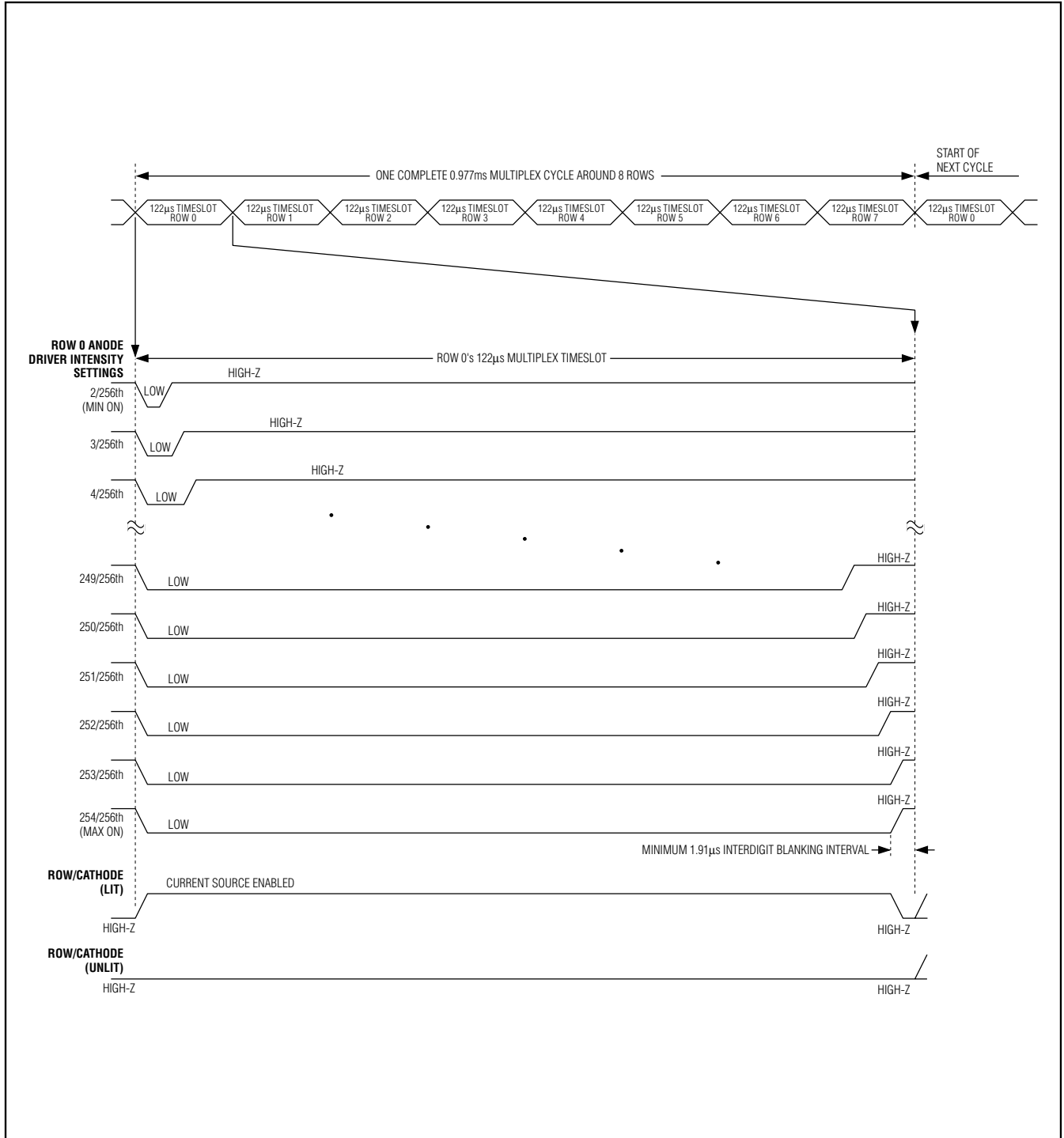

Figure 11. Multiplex Timing Diagram (No Flip; OSC = 4.194304MHz)

4-Wire Serially Interfaced 8 x 8 Matrix Graphic LED Drivers

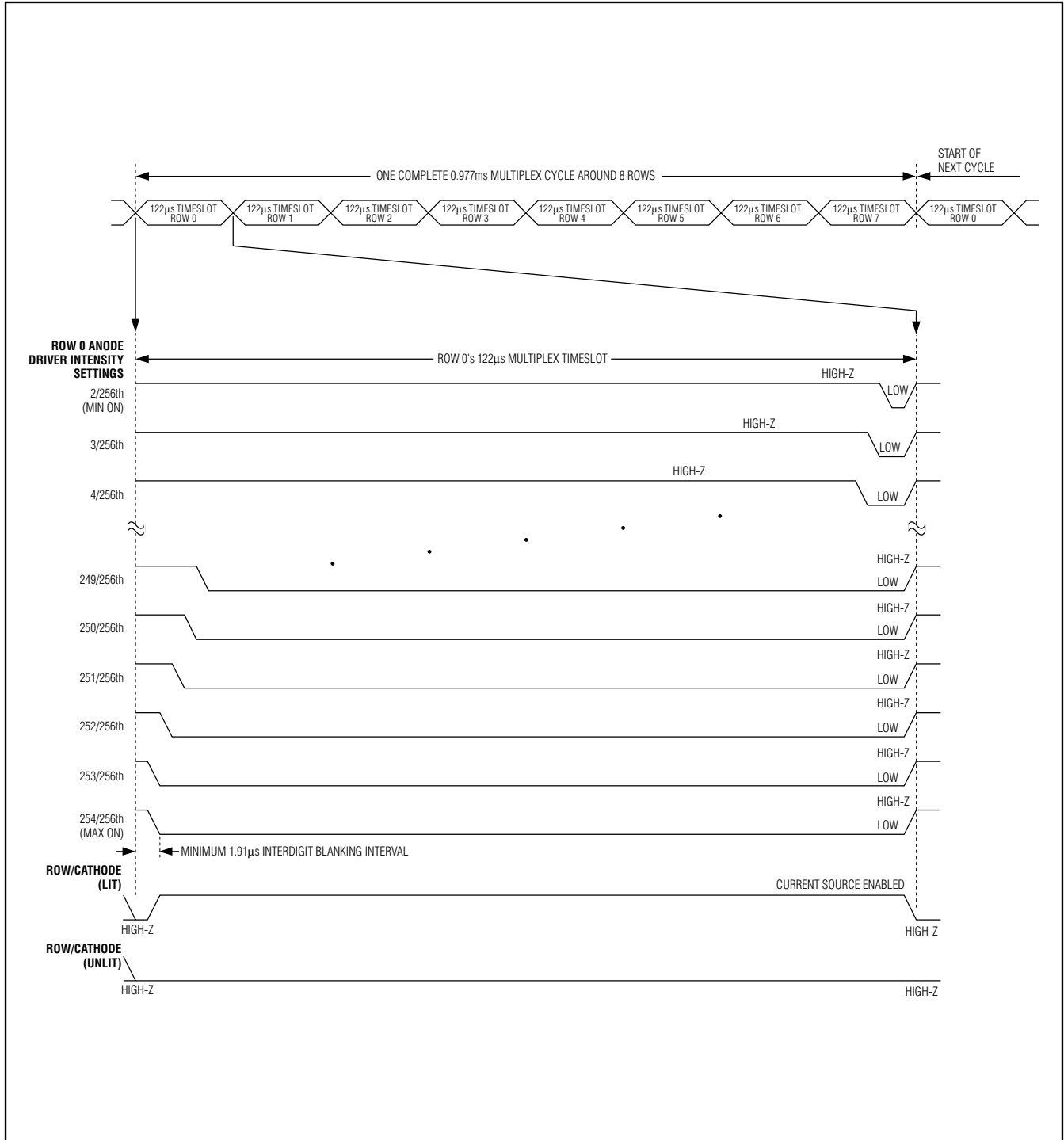

Figure 12. Multiplex Timing Diagram (Flipped; OSC = 4.194304MHz)

4-Wire Serially Interfaced 8 x 8 Matrix Graphic LED Drivers

MAX6960-MAX6963

Table 25. Digit 0 Intensity Register Format

REGISTER	ADDRESS CODE (HEX)	REGISTER DATA							
		D7	D6	D5	D4	D3	D2	D1	D0
0/256	0x03	0	0	0	0	0	0	0	0
1/256	0x03	0	0	0	0	0	0	0	1
2/256	0x03	0	0	0	0	0	0	1	0
3/256	0x03	0	0	0	0	0	0	1	1
4/256	0x03	0	0	0	0	0	1	0	0
—	0x03	—	—	—	—	—	—	—	—
251/256	0x03	1	1	1	1	1	0	1	1
252/256	0x03	1	1	1	1	1	1	0	0
253/256	0x03	1	1	1	1	1	1	0	1
254/256	0x03	1	1	1	1	1	1	1	0
255/256 (max on)	0x03	1	1	1	1	1	1	1	1

Table 26. Digit 1 Intensity Register Format

REGISTER	ADDRESS CODE (HEX)	REGISTER DATA							
		D7	D6	D5	D4	D3	D2	D1	D0
0/256	0x04	0	0	0	0	0	0	0	0
1/256	0x04	0	0	0	0	0	0	0	1
2/256	0x04	0	0	0	0	0	0	1	0
3/256	0x04	0	0	0	0	0	0	1	1
4/256	0x04	0	0	0	0	0	1	0	0
—	0x04	—	—	—	—	—	—	—	—
251/256	0x04	1	1	1	1	1	0	1	1
252/256	0x04	1	1	1	1	1	1	0	0
253/256	0x04	1	1	1	1	1	1	0	1
254/256	0x04	1	1	1	1	1	1	1	0
255/256 (max on)	0x04	1	1	1	1	1	1	1	1

Current Plane Identification (Bits D2, D3)

The current plane bits in the global panel configuration register identify which memory plane is currently being used to control the display panel (Table 18). These bits are read only; written data is ignored.

Ripple Sync (Bit D4)

The ripple sync feature, when enabled in the global panel configuration register, desynchronizes the multiplex timing of all the interconnected MAX6960 drivers on a display panel by OSC/4 (Table 19). This delay spreads the drive transitions among the drivers to spread power-supply peak-current demand, and ease decoupling. The maximum delay from first driver to last driver is 244μs with the maximum of 256 drivers used. This is too short a time to cause visible artifacts.

Mux Flip (Bit D5)

The mux flip feature in the global panel configuration register reverses the panel PWM timing for alternate drivers when enabled (Table 20). Again, this spreads power-supply peak-current demand.

Color Control (Bit D6)

The color control bit in the global panel configuration register selects whether a monochrome or RGY display panel is built. Select monochrome when building an RGB panel as shown in Figure 17. This bit is fixed at zero for the MAX6962 and MAX6963, and a write to this bit is ignored for these parts.

4-Wire Serially Interfaced 8 x 8 Matrix Graphic LED Drivers

Table 27. Panel Intensity Register Format

REGISTER	ADDRESS CODE (HEX)	REGISTER DATA							
		D7	D6	D5	D4	D3	D2	D1	D0
2/256 (min on)	0x02	0	0	0	0	0	0	0	0
	0x02	0	0	0	0	0	0	0	1
	0x02	0	0	0	0	0	0	1	0
3/256	0x02	0	0	0	0	0	0	1	1
4/256	0x02	0	0	0	0	0	1	0	0
5/256	0x02	0	0	0	0	0	1	0	1
—	0x02	—	—	—	—	—	—	—	—
251/256	0x02	1	1	1	1	1	0	1	1
252/256	0x02	1	1	1	1	1	1	0	0
253/256	0x02	1	1	1	1	1	1	0	1
254/256	0x02	1	1	1	1	1	1	1	0
255/256 (max on)	0x02	1	1	1	1	1	1	1	1

Table 28. Global Driver Indirect Address Format

REGISTER	ADDRESS CODE (HEX)	REGISTER DATA							
		D7	D6	D5	D4	D3	D2	D1	D0
Global driver indirect address	0x08	MSB	8-bit driver indirect address 0x00 to 0xFF						LSB

Planes/Intensity Control (Bit D7)

The planes/intensity (PI) control bit in the global panel configuration register selects whether the display memory is configured as four planes with 1-bit-per-pixel per color-intensity control, or two planes with 2-bits-per-pixel per color-intensity control. This bit is fixed at zero for the MAX6961 and MAX6963, and a write to this bit is ignored for these parts.

Pixel Intensity Scale Register

The pixel intensity scale register (Table 24) sets the graduation type used when 2-bits-per-pixel intensity control is selected by setting the PI bit (Table 22). The pixel level-intensity control can be set to be either arithmetic (off, 1/3, 2/3, full) or geometric (off, 1/4, 1/2, full). The setting is made on a digit-by-digit basis, so each color on an RGY or RGB panel can use the most appropriate graduation type.

Digit Intensity Control

The digit 0 and digit 1 intensity registers (Tables 25 and 26) set the fractions of the panel intensity PWM value that are applied to the two display digits. The PWM for each digit is calculated as $n/256$ th of the panel intensity value, where n is the value in the digit's digit 0/1 intensity register. The digit 0/1 intensity registers enable configuring relative adjustments in digit intensity, while the

display panel is still controlled as a whole by the panel intensity. These adjustments are typically used to calibrate out luminosity differences between LEDs from different batches. They can also be used to color balance RGY displays so that, for example, full panel intensity of a red-green panel is a consistent orange hue.

Panel Intensity Control

Digital control of panel display brightness is provided by an internal pulse-width modulator, which is controlled by the panel intensity register (Table 27). The modulator scales the average segment current in 253 steps from a maximum of 255/256 down to 2/256 of the peak current. The maximum effective PWM duty cycle for a digit is therefore 254/256, given by the maximum 255/256 digit intensity multiplied by the maximum 255/256 panel intensity. The minimum interdigit blanking time is therefore 4/256 of a cycle, or $4/256 \times 122\mu\text{s}$ digit period = 1.91 μs .

Peak-Segment Current Selection

The LED drive current can be selected between either a 40mA peak per segment and a lower 20mA peak current on a digit-by-digit basis using the R_{IS}ET₀ and R_{IS}ET₁ pins. R_{IS}ET₀ should be open circuit to select 20mA, or connected to GND to select 40mA segment current for digit 0. R_{IS}ET₁ selects segment current for

4-Wire Serially Interfaced 8 x 8 Matrix Graphic LED Drivers

MAX6960-MAX6963

Table 29. Global Display Indirect Address Format

REGISTER	ADDRESS CODE (HEX)	REGISTER DATA							
		D7	D6	D5	D4	D3	D2	D1	D0
Global display indirect address LSB	0x09	D7	D6	D5	D4	D3	D2	D1	D0
Global display indirect address MSB	0x0A	X	X	D13	D12	D11	D10	D9	D8

Table 30. Global Plane Counter Register Format

REGISTER	PLANES/INTENSITY BIT (SEE TABLE 22): 0 FOR 1 BIT/PIXEL; 4 PLANES 1 FOR 1 BIT/PIXEL; 4 PLANES	ADDRESS CODE (HEX)	REGISTER DATA							
			D7	D6	D5	D4	D3	D2	D1	D0
PLANE COUNTER	—	0x0B	Fast slow	Auto manual	Counter setting					
Manual selection to plane 0—counter disabled	X	0x0B	X	0	X	X	X	X	0	0
Manual selection to plane 1—counter disabled	X	0x0B	X	0	X	X	X	X	0	1
Manual selection to plane 2—counter disabled	0	0x0B	X	0	X	X	X	X	1	0
Manual selection to plane 0—counter disabled	1	0x0B	X	0	X	X	X	X	1	1
Manual selection to plane 3—counter disabled	0	0x0B	X	0	X	X	X	X	1	0
Manual selection to plane 1—counter disabled	1	0x0B	X	0	X	X	X	X	1	1
SLOW PLANE COUNTER			0	1	X	X	X	X	X	X
Auto slow plane counter—1 frame every second	—	0x0B	0	1	0	0	0	0	0	1
Auto slow plane counter—1 frame every 2s	—	0x0B	0	1	0	0	0	0	1	0
—			0	1	—	—	—	—	—	—
Auto slow plane counter—1 frame every 62s	—	0x0B	0	1	1	1	1	1	1	0
Auto slow plane counter—1 frame every 63s	—	0x0B	0	1	1	1	1	1	1	1
FAST PLANE COUNTER			1	1	X	X	X	X	X	X
Auto fast plane counter—1 frame per second	—	0x0B	1	1	0	0	0	0	0	1

4-Wire Serially Interfaced 8 x 8 Matrix Graphic LED Drivers

Table 30. Global Plane Counter Register Format (continued)

REGISTER	PLANES/INTENSITY BIT (SEE TABLE 22): 0 FOR 1 BIT/PIXEL; 4 PLANES 1 FOR 1 BIT/PIXEL; 4 PLANES	ADDRESS CODE (HEX)	REGISTER DATA							
			D7	D6	D5	D4	D3	D2	D1	D0
PLANE COUNTER		0x0B	Fast slow	Auto manual	Counter setting					
Auto fast plane counter—2 frames per second		0x0B	1	1	0	0	0	0	1	0
—			1	1	—	—	—	—	—	—
Auto fast plane counter—62 frames per second		0x0B	1	1	1	1	1	1	1	0
Auto fast plane counter—63 frames per second		0x0B	1	1	1	1	1	1	1	1

digit 1 in the same manner. The MAX6960 is guaranteed to drive 40mA peak segment current into a 2.4V LED with a minimum supply voltage of 3.15V, and 20mA peak segment current into a 2.2V LED with a minimum supply voltage of 2.7V.

Global Driver Indirect Address Register

The global driver indirect address register is used to store the driver address identifying which of 256 MAX6960s is accessed for 16-bit transmission when a local register is read (Table 28).

Global Display Indirect Address Register

The global display indirect address registers are used to store the 14-bit display memory address identifying which byte of display memory across all the interconnected MAX6960s is written by an 8-bit transmission (Table 29). The 14-bit address stored in these two registers increments after every 8-bit transmission, and overflows from address 0x3FFF to address 0x0000.

Global Plane Counter

The global plane counter (Table 30) allows any display plane to be selected as the current display plane, or configures the MAX6960 for automatic plane sequencing. The display plane is switched to the newly selected plane on the rising edge of \overline{CS} at the end of the 16-bit transmission. When automatic plane sequencing is selected, the current display plane is initialized to plane P0. The current display plane is incremented through all four planes P0–P3 (planes/intensity = 0) or both planes P0–P1 (planes/intensity = 1) at the frame rate selected, and then restarts at plane P0 again. The

plane sequencing continues until the global plane counter is reconfigured. If the global plane counter is used for the automatic sequencing of animations, the user should ensure that the plane ahead of the current display plane is updated before the automatic plane switchover to achieve artifact-free animation.

Global Clear Planes Command

Writing the global clear planes counter (Table 31) allows any or all display memory planes to be cleared with one command. The selected plane(s) are cleared on the rising edge of \overline{CS} at the end of the 16-bit transmission.

Fault Detection

LED Fault Detection

The MAX6960 detects open-circuit and short-circuit LEDs. It can only detect an LED fault when attempting to light that LED, so a good strategy to check a panel is to program the panel with all LEDs on power-up to check the displays.

The fault and device ID register (Table 32) uses 3 bits to flag and distinguish open-circuit (open flag), short circuit (short flag), and overtemperature (OT flag) faults, and a fourth flag (fault flag), which is an OR of the open flag, short flag, and OT flag.

The fault and device ID register is cleared on power-up, and can also be cleared by writing to it. The fault flags are NOT cleared by a read. When writing the fault and device ID register, the data written is ignored; all fault flags are cleared, including the OT flag. It is possible to clear all MAX6960s on a bus by performing a global write to the fault and device ID register.

4-Wire Serially Interfaced 8 x 8 Matrix Graphic LED Drivers

MAX6960-MAX6963

Table 31. Global Clear Planes Register Format

ACTION	ADDRESS CODE (HEX)	REGISTER DATA							
		D7	D6	D5	D4	D3	D2	D1	D0
GLOBAL CLEAR PLANES	0x0C	GREEN P3	GREEN P2	GREEN P1	GREEN P0	RED P3	RED P2	RED P1	RED P0
Clear all red plane P0 display memory	0x0C	X	X	X	X	X	X	X	1
Clear all red plane P1 display memory	0x0C	X	X	X	X	X	X	1	X
Clear all red plane P2 display memory*	0x0C	X	X	X	X	X	1	X	X
Clear all red plane P3 display memory*	0x0C	X	X	X	X	1	X	X	X
Clear all green plane P0 display memory†	0x0C	X	X	X	1	X	X	X	X
Clear all green plane P1 display memory†	0x0C	X	X	1	X	X	X	X	X
Clear all green plane P2 display memory†	0x0C	X	1	X	X	X	X	X	X
Clear all green plane P3 display memory†	0x0C	1	X	X	X	X	X	X	X

*These bit settings are ignored when the global panel configuration register bit PI is clear (i.e., ignored in 2-bits-per-pixel mode).

†These bit settings are ignored when the global panel configuration register bit C is clear (i.e., ignored in monochrome mode).

Table 32. Fault and Device ID Register Format

REGISTER	ADDRESS CODE (HEX)	REGISTER DATA							
		D7	D6	D5	D4	D3	D2	D1	D0
Fault (read)	0x05	Fault flag	Part ID		X	X	OT flag	Short flag	Open flag
Fault (write) clears fault register status	0x05	0	Part ID		X	X	0	0	0
Device is MAX6960	0x05	X	0	0	X	X	X	X	X
Device is MAX6961	0x05	X	0	1	X	X	X	X	X
Device is MAX6962	0x05	X	1	0	X	X	X	X	X
Device is MAX6963	0x05	X	1	1	X	X	X	X	X
No LED or OT faults	0x05	0	Part ID		X	X	0	0	0
At least one open-circuit LED fault	0x05	1	Part ID		X	X	X	X	1
At least one short-circuit LED fault	0x05	1	Part ID		X	X	X	1	X
Overtemperature fault	0x05	1	Part ID		X	X	1	X	X

4-Wire Serially Interfaced 8 x 8 Matrix Graphic LED Drivers

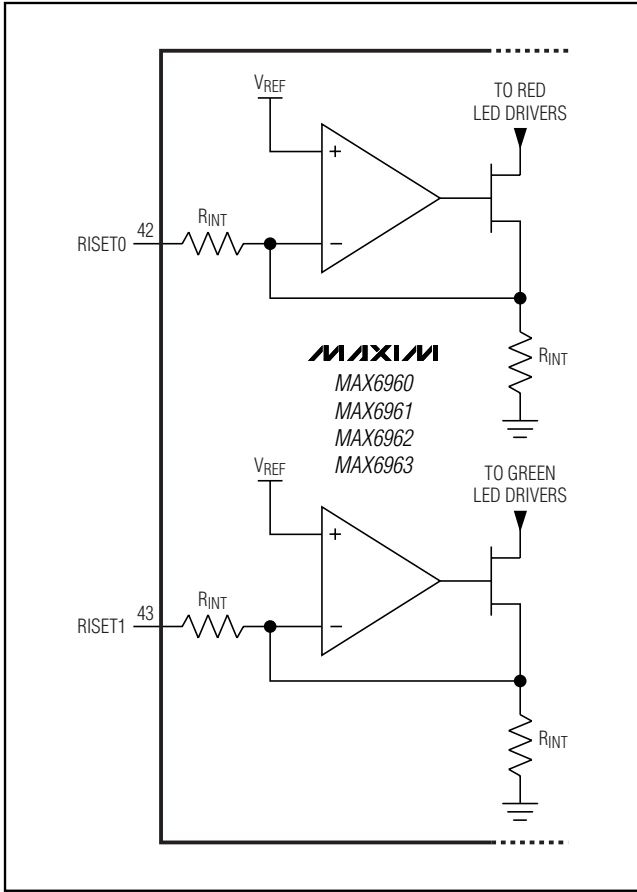

Figure 13. RISET0 and RISET1 Internal Architecture

Overtemperature Fault Detection

The MAX6960 contains an overtemperature (OT) detection circuit, which trips at a die temperature of typically +150°C. The OT event is latched, and is readable in the fault and device ID register (Table 32). When the OT trips, the MAX6960 shutdown bit in the configuration register (Table 15) is cleared, and the driver goes into shutdown. Data is not lost; the effect is the same as the user setting the shutdown bit. The user can attempt to set the shutdown bit at any time. However, if the driver is still over temperature, then the attempt to set the shutdown bit is ignored. The OT fault flag is NOT automatically cleared when the device cools, or when the device is taken out of shutdown.

The fault and device ID register is cleared on power-up, and can also be cleared by writing to it. The fault flags are NOT cleared by a read. When writing the fault and device ID register, the data written is ignored; all fault flags are cleared, including the LED flags. It is possible to clear all MAX6960s on a bus by performing a global write to the fault and device ID register.

Applications Information

Setting LED Drive Current

The MAX6960 can be configured for pretrimmed 20mA or 40mA LED current, or a 20mA to 40mA adjustable current, on a digit-by-digit basis by the RISET0 and RISET1 pin connections (Figures 13 and 14). The digit intensity registers can be used to digitally adjust the segment current, again on a digit-by-digit basis, by controlling the PWM. Some applications best use one or the other technique; some applications may require the flexibility of both.

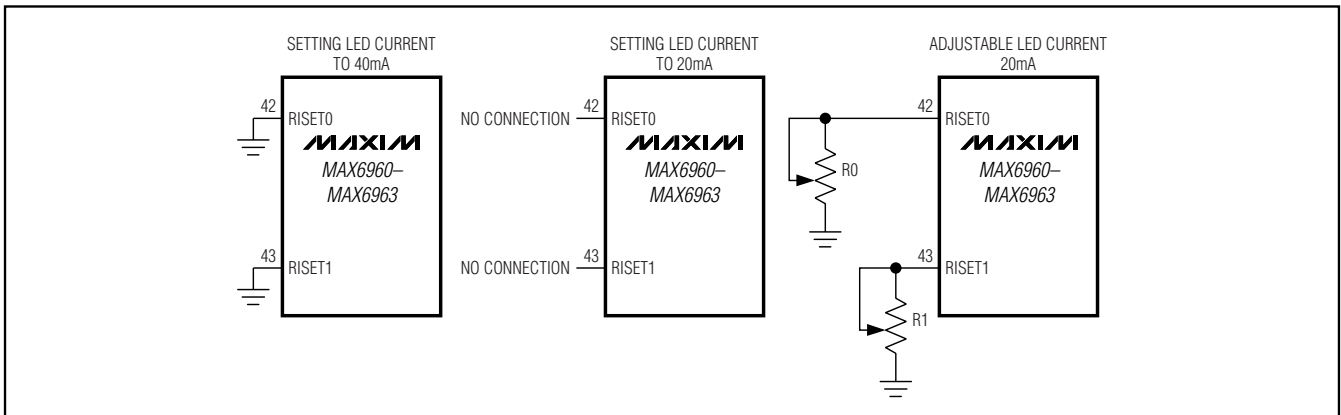

Figure 14. RISET0 and RISET1 Pin Connections

4-Wire Serially Interfaced 8 x 8 Matrix Graphic LED Drivers

Power Supplies

The MAX6960 operates from a single 2.7V to 3.6V power supply. Accuracy of the LED drive current of 20mA is guaranteed over this supply range. Accuracy of the LED drive current of 40mA is guaranteed over a supply range of 3.15V to 3.6V.

Bypass each of the 5 V+ power-supply pins to GND with a 0.1 μ F capacitor as close to the device as possible. Add a 10 μ F to 100 μ F bulk decoupling capacitor to the supply bus at least every several MAX6960s. Each MAX6960 draws a peak current of either 40mA x 16 segments = 640mA (current setting = high) or 20mA x 16 segments = 320mA (current setting = low), regardless of the PWM plane and pixel intensity settings. If ripple sync and/or mux flip are enabled, then the timing of these peak currents is desynchronized between drivers, providing an easier load to the power supply. For all but the smallest display panels, it is necessary to use 2oz copper boards to minimize the voltage drops across the supply planes with the high currents that are required. Set the supply voltage to 3.6V at the panel supply input to allow the most margin for on-board supply voltage drops. For the TQFN package, connect the exposed pad to GND.

RST Input

The external reset input, $\overline{\text{RST}}$, is asserted low and halts internal operations and forces control registers to their default values shown in Table 12. In systems where the MAX6960s are operated from different regulated supplies with different power-up delays, hold $\overline{\text{RST}}$ of every interconnected MAX6960 low until 50ms after the last MAX6960 has powered up. $\overline{\text{RST}}$ can be asserted low at any time to force all devices to the default condition. $\overline{\text{RST}}$ must be driven by a CMOS logic output supplied by V+. A supervisor, such as the MAX6821x526, which has an adjustable power-up reset delay, is a good choice.

When $\overline{\text{RST}}$ is deasserted, the sequence of events for writing global registers and auto-address configuration is the same as described in the *Initial Power-Up* section.

Package Dissipation

Typical full-power (all segments on) device power dissipation is 671mW ($V_+ = 3.3\text{V}$, $V_{\text{LED}} = 2.3\text{V}$, $I_{\text{LED}} = 40\text{mA}$, 254/256 full intensity). Consider the effect of one or more shorted display LEDs in planning dissipation handling. The MAX6960 remains under the 1023mW MQFP package dissipation limit at +70°C with $V_+ = 3.6\text{V}$ and $V_{\text{LED}} = 2.1\text{V}$. The TQFN package is preferred for 40mA segment current applications because the

2.16W package dissipation limit easily handles worst-case applications including multiple shorted LEDs.

Connecting Multiple MAX6960s to the 4-Wire Bus

Up to 256 MAX6960s can be interconnected to share the same 4-wire bus in parallel, sharing a common $\overline{\text{CS}}$. The maximum of 256 devices is set by the automatic address allocation limit. Care is needed to achieve the successful parallel interconnection of more than 16 MAX6960s due to the high-capacitive loading this presents onto the 4-wire bus. It is generally necessary to either buffer and drive the CLK, DIN, and $\overline{\text{CS}}$ lines to small groups of drivers, or to reduce the 4-wire data rate from the 20Mb/s limit, if more than approximately 16 MAX6960s are used. The exact limit depends on the application's 4-wire data rate requirement, the capacitive drive capability of the host's CLK, DIN, and $\overline{\text{CS}}$ drivers, and the effective capacitance of the CLK, DIN, and $\overline{\text{CS}}$ routing on the circuit board. The circuit in Figure 15 shows one way of fanning out the CLK, DIN, and $\overline{\text{CS}}$ lines to 128 MAX6960s, and fanning in the DOUT lines back into one DOUT line. The CLK, DIN, and $\overline{\text{CS}}$ lines are buffered with standard CMOS bus buffers, with each buffer output driving 16 CLK, DIN, or $\overline{\text{CS}}$ inputs. The tri-state DOUT outputs are also connected together in groups of 16, and fed into octal analog multiplexers. The analog multiplexers are used here as data selectors, with the very low (10 Ω) switch resistance providing an effective logic power driver. Note, however, that while the MAX6960's DOUT output is tri-state, the selected DOUT from this power driver is not.

Using the MAX6960 as Controller for Higher Voltage or Higher Current

The MAX6960 can be used as a graphic controller with external drive transistors for applications requiring higher peak segment currents and/or a higher drive voltage (multiple LEDs in series for each pixel). The panel and pixel-level intensity control is still available because PWM techniques are used, but the peak segment current is set by external current-limiting resistors in series with the LEDs, instead of the MAX6960's internal precision constant-current sources. Figure 16 shows example output drivers that interface the MAX6960 to control anode-row displays at a higher segment current and drive voltage. Sixteen instances of the low-current cathode column driver, and eight instances of the high-current anode row driver are required per MAX6960.

4-Wire Serially Interfaced 8 x 8 Matrix Graphic LED Drivers

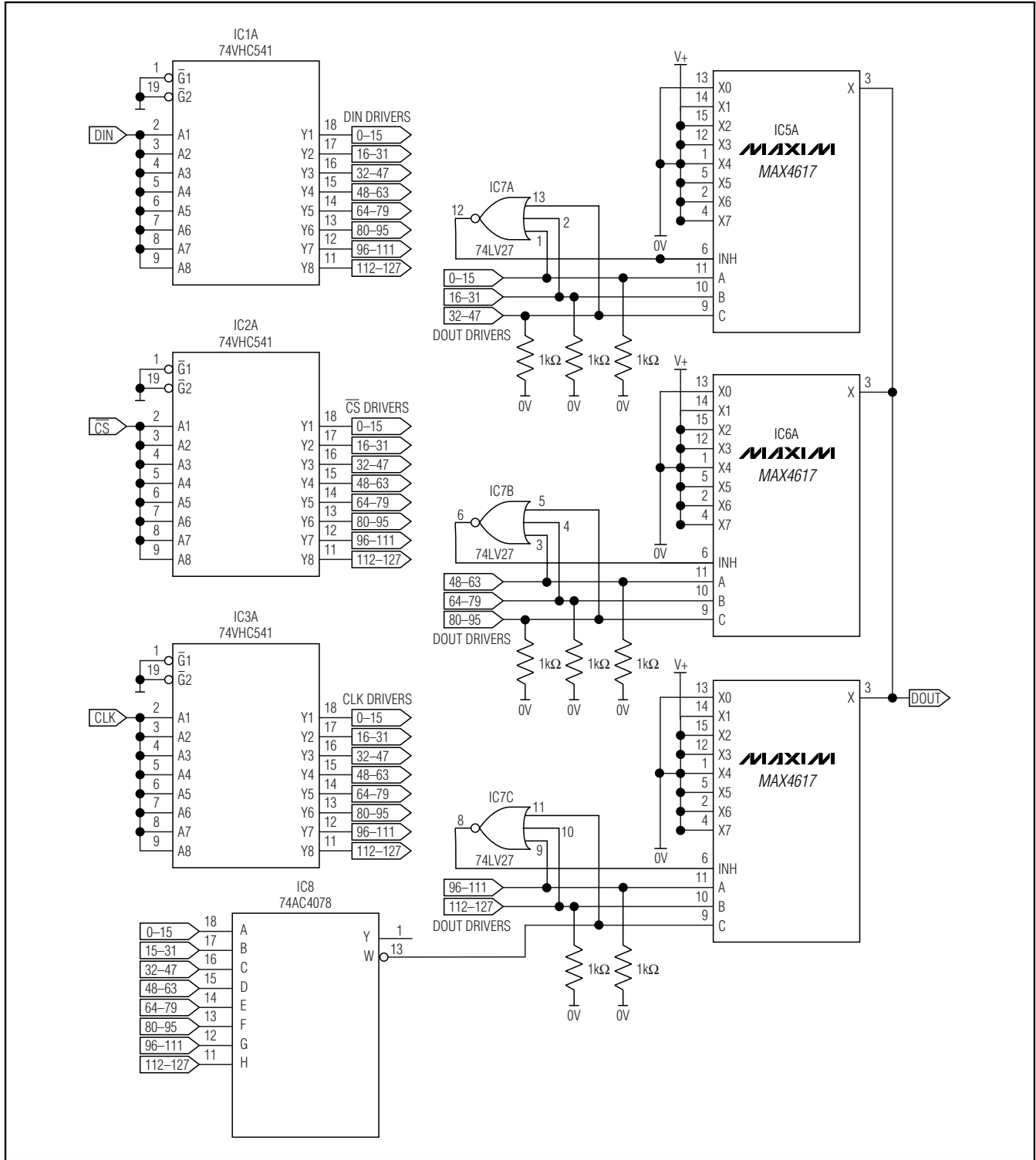

Figure 15. MAX6960-MAX6963 High-Speed 4-Wire Interface Expansion

4-Wire Serially Interfaced 8 x 8 Matrix Graphic LED Drivers

To use these drivers, choose R1 to set the desired peak segment current I_{PEAK} according to the driver supply voltage V_{DRIVER} and the LED forward voltage drop V_{LED} :

$$I_{PEAK} = \frac{(V_{DRIVER} - V_{LED} - V_{CE(SAT)Q1})}{(R1 + R_{DS(ON)Q2})} A$$

Choose R2 to pass 5mA in order to drop 5V across R3 to provide 5V gate drive to logic-level pFET Q2:

$$R2 = (V_{DRIVER} - V_{CE(SAT)Q3} - 5) \times 200\Omega$$

Rate Q1 at segment current I_{PEAK} , and rate Q2 at row current, which is 16 times I_{PEAK} .

Using the MAX6960 as Driver/Controller for RGB Displays

A MAX6960 can drive an 8 x 16 LED matrix, and so one MAX6960 can drive two 8 x 8 monochrome digits or one 8 x 8 RGY digit. A MAX6960 cannot directly drive an 8 x 8 RGB display digit, but MAX6960s can nevertheless be used to build RGB panels.

The MAX6960 drivers provide 3 x 2 = 6 bits of color control to an RGB panel, or 64 colors.

The best way to drive RGB LEDs with the MAX6960 is to use three 3-wire buses, one for each color (Figure 17). A single 4-wire interface must be used, with three CSs,

again one for each color. The red and green LEDs are driven directly by their MAX6960s, and are connected cathode row as normal. The blue LEDs cannot be driven directly by their MAX6960s because the blue LED forward voltage is too high, so external drive transistors must be used as discussed previously. The blue LEDs are therefore connected anode row. The MAX6960 is suitable to drive discrete RGB matrix displays using either separate LEDs for the red, green, and blue or six-terminal surface-mount or through-hole RGB LEDs. The six-terminal LEDs must be used to give individual access to the anodes and cathodes. The MAX6960 is not suitable to drive prewired RGB 8 x 8 matrix displays because the row/column wiring is incorrect.

Synchronization is achieved by writing the global panel configuration registers for every driver at the same time. The user must therefore provide a method for driving all three CSs together when writing the global panel configuration register. This complexity aside, the three-bus method automatically organizes the display memory into three color planes. Also, ripple sync and mux flip can be enabled or disabled in any manner desired. The digit limit for one set of three 3-wire buses is 768 RGB digits using 256 MAX6960s. The structure can be repeated to build a very large panel.

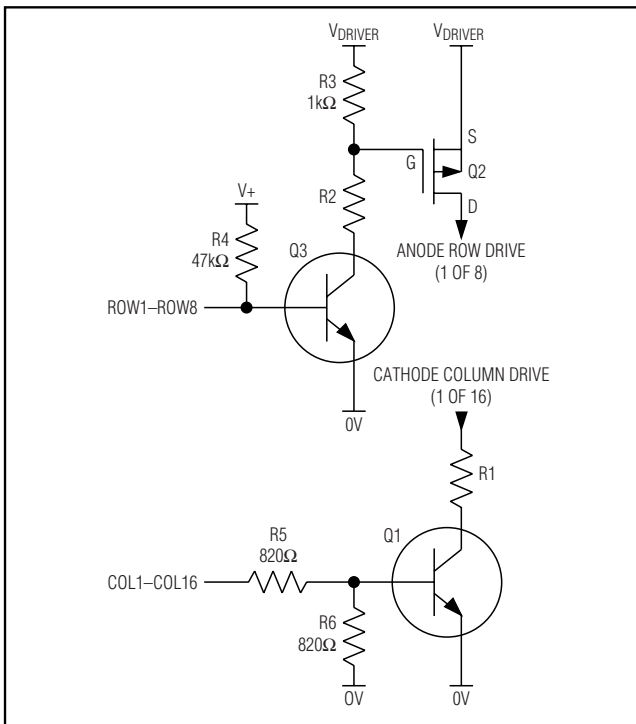
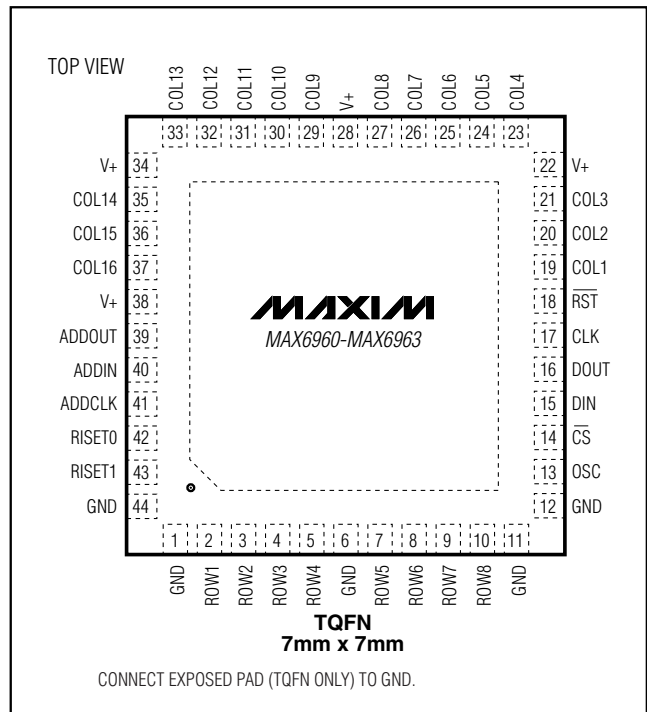

Figure 16. Current and Voltage Boosting MAX6960-MAX6963 with External Transistors

Pin Configurations (continued)



4-Wire Serially Interfaced 8 x 8 Matrix Graphic LED Drivers

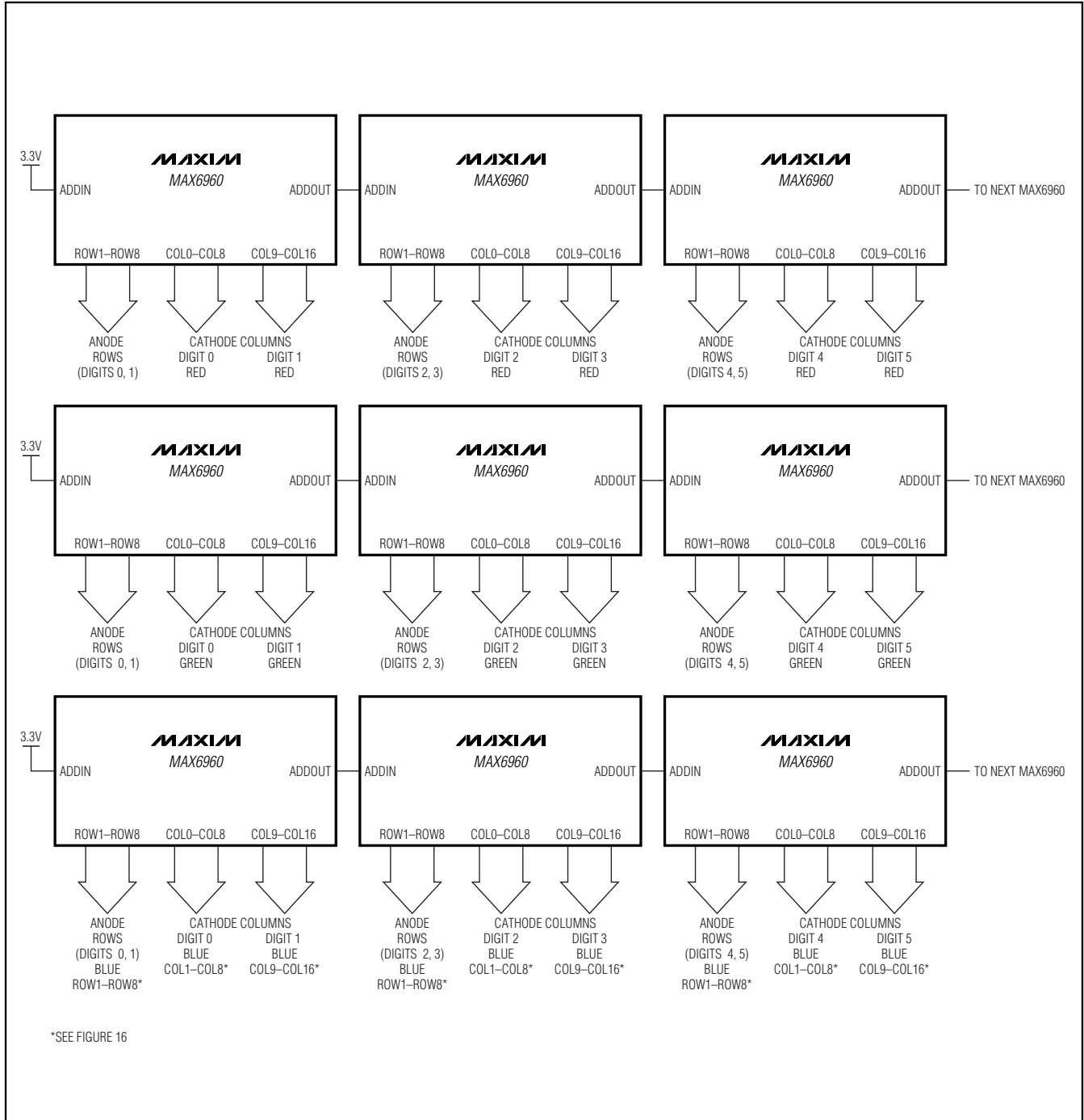

Figure 17. Connecting MAX6960-MAX6963s to RGB Displays

4-Wire Serially Interfaced 8 x 8 Matrix Graphic LED Drivers

Package Information

(The package drawing(s) in this data sheet may not reflect the most current specifications. For the latest package outline information go to www.maxim-ic.com/packages.)

MAX6960-MAX6963

MQFP44,EP5

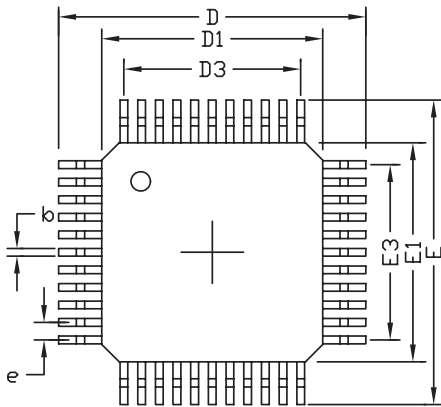

DIM	MILLIMETERS		INCHES	
	MIN	MAX	MIN	MAX
A	--	2.45	--	0.096
A1	0.000	0.250	0.000	0.010
A2	1.800	2.200	0.071	0.087
b	0.290	0.450	0.011	0.018
c	0.110	0.230	0.004	0.009
D	12.954	13.462	0.510	0.530
D1	9.906	10.109	0.390	0.398
D3	8.000	REF	0.315	REF
E	12.954	13.462	0.510	0.530
E1	9.906	10.109	0.390	0.398
E3	8.000	REF	0.315	REF
e	0.800	REF	0.031	REF
L	0.730	1.030	0.029	0.041
α	*0	*7	*0	*7

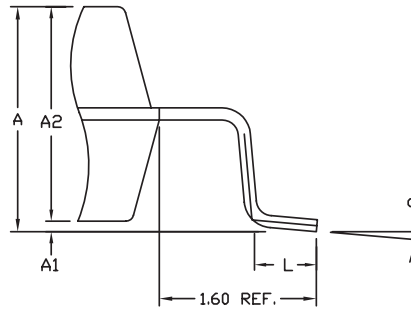
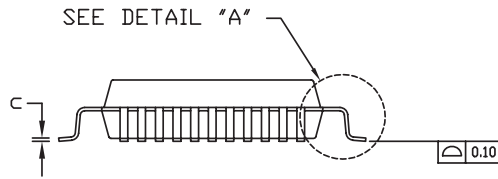

DETAIL "A"

NOTES:

1. D1&E1 DO NOT INCLUDE MOLD FLASH.
2. MOLD FLASH OR PROTRUSIONS NOT TO EXCEED 0.25mm(0.010").
3. CONTROLLING DIMENSION: MILLIMETER.
4. MEETS JEDEC MS-022-AB.

PROPRIETARY INFORMATION		
TITLE: PACKAGE OUTLINE 44L MQFP, 1.60 LEAD FORM		
APPROVAL	DOCUMENT CONTROL NO. 21-0826	REV. D 1/1

4-Wire Serially Interfaced 8 x 8 Matrix Graphic LED Drivers

Package Information (continued)

(The package drawing(s) in this data sheet may not reflect the most current specifications. For the latest package outline information go to www.maxim-ic.com/packages.)

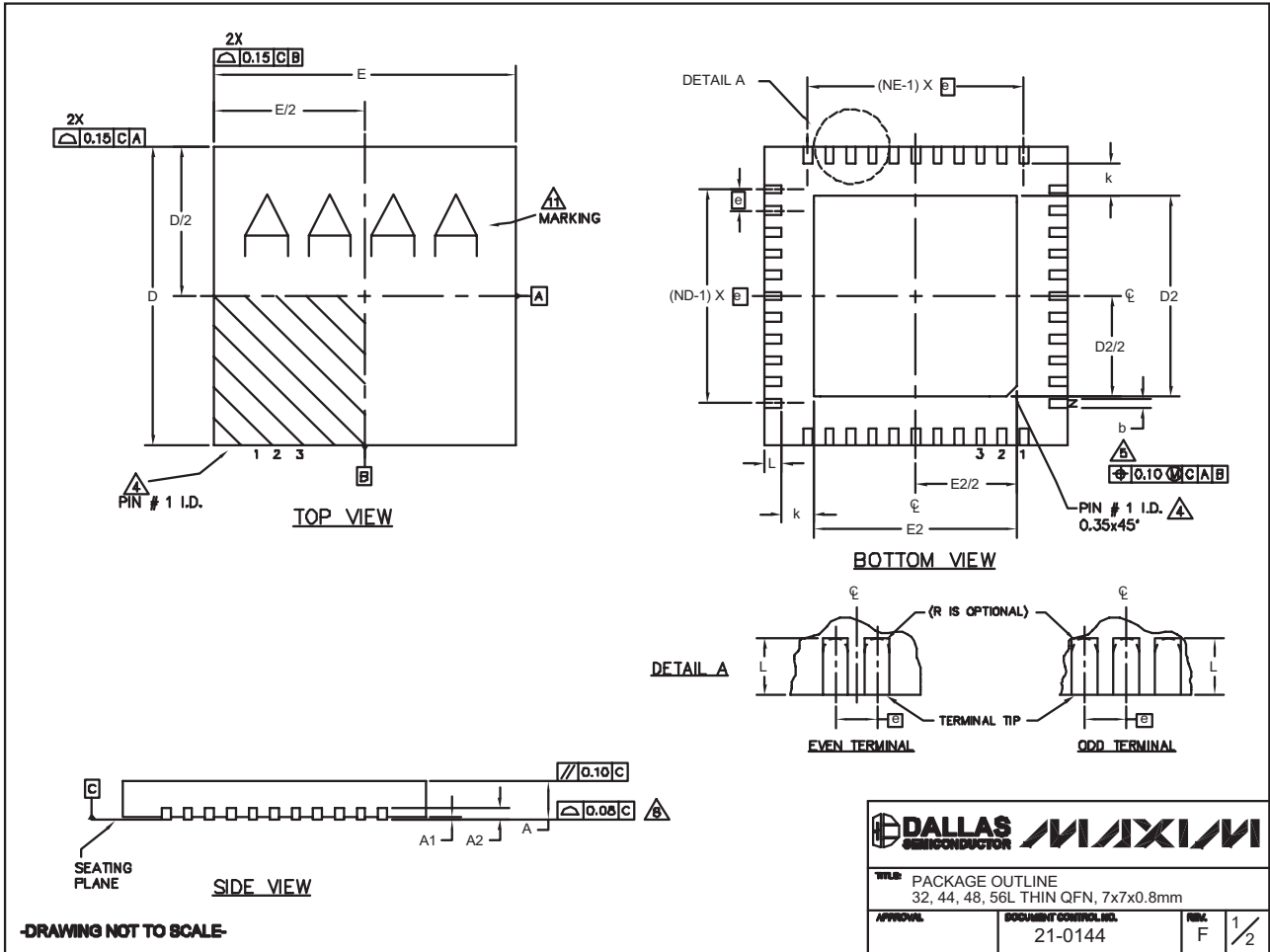

32, 44, 48L QFN/EP

4-Wire Serially Interfaced 8 x 8 Matrix Graphic LED Drivers

Package Information (continued)

(The package drawing(s) in this data sheet may not reflect the most current specifications. For the latest package outline information go to www.maxim-ic.com/packages.)

MAX6960-MAX6963

COMMON DIMENSIONS															EXPOSED PAD VARIATIONS												
PKG	32L 7x7			44L 7x7			48L 7x7			CUSTOM PKG. (T4877-1) 48L 7x7			56L 7x7			PKG. CODES	DEPOPULATED LEADS	D2			E2			JEDEC MO220 REV. C			
	MIN.	NOM.	MAX.	MIN.	NOM.	MAX.	MIN.	NOM.	MAX.	MIN.	NOM.	MAX.	MIN.	NOM.	MAX.			MIN.	NOM.	MAX.	MIN.	NOM.	MAX.				
A	0.70	0.75	0.80	0.70	0.75	0.80	0.70	0.75	0.80	0.70	0.75	0.80	0.70	0.75	0.80	T3277-2	-	4.55	4.70	4.85	4.55	4.70	4.85	-			
A1	0	0.02	0.05	0	0.02	0.05	0	0.02	0.05	0	0.02	0.05	0	0.02	0.05	T3277-3	-	4.55	4.70	4.85	4.55	4.70	4.85	-			
A2	0.20 REF.			0.20 REF.			0.20 REF.			0.20 REF.			0.20 REF.			T4477-2	-	4.55	4.70	4.85	4.55	4.70	4.85	WKD-1			
b	0.25	0.30	0.35	0.20	0.25	0.30	0.20	0.25	0.30	0.20	0.25	0.30	0.20	0.25	0.30	0.15	0.20	0.25	T4477-3	-	4.55	4.70	4.85	4.55	4.70	4.85	WKD-1
D	6.90	7.00	7.10	6.90	7.00	7.10	6.90	7.00	7.10	6.90	7.00	7.10	6.90	7.00	7.10	6.90	7.00	7.10	T4877-1**	13,24,37,48	4.20	4.30	4.40	4.20	4.30	4.40	-
E	6.90	7.00	7.10	6.90	7.00	7.10	6.90	7.00	7.10	6.90	7.00	7.10	6.90	7.00	7.10	6.90	7.00	7.10	T4877-3	-	4.95	5.10	5.25	4.95	5.10	5.25	-
e	0.65 BSC.			0.50 BSC.			0.50 BSC.			0.50 BSC.			0.40 BSC.			T4877-4	-	5.40	5.50	5.60	5.40	5.50	5.60	-			
k	0.25	-	-	0.25	-	-	0.25	-	-	0.25	-	-	0.25	-	-	0.25	-	-	T4877-5	-	2.40	2.50	2.60	2.40	2.50	2.60	-
L	0.45	0.55	0.65	0.45	0.55	0.65	0.30	0.40	0.50	0.45	0.55	0.65	0.30	0.40	0.50	T4877-6	-	5.40	5.50	5.60	5.40	5.50	5.60	-			
N	32			44			48			44			56			T4877-7	-	4.95	5.10	5.25	4.95	5.10	5.25	-			
ND	8			11			12			10			14			T4877M-1	-	5.40	5.50	5.60	5.40	5.50	5.60	-			
NE	8			11			12			12			14			T4877M-6	-	5.40	5.50	5.60	5.40	5.50	5.60	-			
																T4877M-8	-	5.40	5.50	5.60	5.40	5.50	5.60	-			
																T5677-1	-	5.40	5.50	5.60	5.40	5.50	5.60	-			
																T5677-2	-	5.40	5.50	5.60	5.40	5.50	5.60	-			

** NOTE: T4877-1 IS A CUSTOM 48L PKG. WITH 4 LEADS DEPOPULATED. TOTAL NUMBER OF LEADS ARE 44.

NOTES:

1. DIMENSIONING & TOLERANCING CONFORM TO ASME Y14.5M-1994.
2. ALL DIMENSIONS ARE IN MILLIMETERS. ANGLES ARE IN DEGREES.
3. N IS THE TOTAL NUMBER OF TERMINALS.
4. THE TERMINAL #1 IDENTIFIER AND TERMINAL NUMBERING CONVENTION SHALL CONFORM TO JESD 95-1 SPP-012. DETAILS OF TERMINAL #1 IDENTIFIER ARE OPTIONAL, BUT MUST BE LOCATED WITHIN THE ZONE INDICATED. THE TERMINAL #1 IDENTIFIER MAY BE EITHER A MOLD OR MARKED FEATURE.
5. DIMENSION b APPLIES TO METALLIZED TERMINAL AND IS MEASURED BETWEEN 0.25 mm AND 0.30 mm FROM TERMINAL TIP.
6. ND AND NE REFER TO THE NUMBER OF TERMINALS ON EACH D AND E SIDE RESPECTIVELY.
7. DEPOPULATION IS POSSIBLE IN A SYMMETRICAL FASHION.
8. COPLANARITY APPLIES TO THE EXPOSED HEAT SINK SLUG AS WELL AS THE TERMINALS.
9. DRAWING CONFORMS TO JEDEC MO220 EXCEPT THE EXPOSED PAD DIMENSIONS OF T4877-1/-3/-4/-5/-6 & T5677-1.
10. WARPAGE SHALL NOT EXCEED 0.10 mm.
11. MARKING IS FOR PACKAGE ORIENTATION REFERENCE ONLY
12. NUMBER OF LEADS SHOWN ARE FOR REFERENCE ONLY

-DRAWING NOT TO SCALE-

TITLE: PACKAGE OUTLINE 32, 44, 48, 56L THIN QFN, 7x7x0.8mm	
APPROVAL	DOCUMENT CONTROL NO. 21-0144
REV. F	2/2

Revision History

Pages changed at Rev 2: 1, 3, 35
Pages changed at Rev 3: 1, 32, 35

Chip Information

TRANSISTOR COUNT: 120,579
PROCESS: BiCMOS

Maxim cannot assume responsibility for use of any circuitry other than circuitry entirely embodied in a Maxim product. No circuit patent licenses are implied. Maxim reserves the right to change the circuitry and specifications without notice at any time.

Maxim Integrated Products, 120 San Gabriel Drive, Sunnyvale, CA 94086 408-737-7600 35